

CASO®

D E S I G N

INNOVATIVE KITCHEN TECHNOLOGY



COMPETENCE BOOK
KITCHEN

THE INNOVATIVE KITCHEN TECHNOLOGY

“Our passion motivates us to develop high-quality, timeless products based on innovative technologies. Over the last few years we have worked continuously to further expand this principle and are proud to present our new range of built-in kitchen appliances.

With more user convenience, great functionality and high performance. Clear design for enjoyable cooking and dining.”

Peter Braukmann, Bernd Braukmann





Table of contents

Air venting hobs	8
The intelligent 2-in-1 solution for modern kitchens	
JET AIR separation technology	14
Turbine power instead of grease filters	
Surface induction hobs	30
Enjoyable cooking plus the greatest possible safety	
Built-in wine coolers	44
For gourmet moments at home – Coolers for the perfect taste experience	
Microwaves	64
Compact cooking pleasure for heating and baking	
Vacuum sealers	68
Perfect, reliable vacuum sealing for fresher food at home	

8



Air venting hobs

30



Surface induction hobs

64



Microwaves

68



Vacuum sealers

44



Built-in wine coolers



Aesthetics and design

Innovative kitchen technology
from CASO Design delivers timeless
design and high quality.





100% cooking pleasure
in modern kitchens

Innovative air
venting hobs



01
49
01



Air venting hobs – The intelligent 2-in-1 solution for modern kitchens

Built-in air venting hobs preserve the clear lines of your space. Our innovative technology delivers two game-changing advantages:

- + Pleasantly fresh air when cooking thanks to patented **JET AIR separation technology**
- + Maximum cooking space for your pots and pans thanks to concentrated airflow

The patented JET AIR system in our hobs cleans air by using the turbine principle to separate and trap particles in the air. This technology requires no grease filter which

can impact performance because it is blocked – Jet Air always delivers maximum cleaning. Efficiency and easy cleaning are the key advantages over filter systems.

Top-class convenience when you cook. The touch screen operating panel allows you to set all the power levels quickly and precisely, while the clear white LED ensures you can see everything at a glance. The integrated heating function automatically controls fast heating up before automatically reducing the temperature to the pre-set power level. More time for perfect enjoyment.



Innovative technology, that convinces



Elegant design in top quality

High-quality CASO Design induction hobs with touch control and elegant slider controls combine two appliances in one product. Patented **JET AIR separation technology** efficiently removes steam and grease particles from air during cooking. No other system offers such quick and easy hygienic cleaning while still leaving you plenty of space to cook. Thanks to the concentrated Jet Air airflow the system requires only a tiny air inlet, ensuring that you have maximum space for large pots and pans and can enjoy cooking to the max.

An additional benefit:
The JET AIR system is space-saving and easy to install.





More convenience – More pleasurable cooking – More enjoyment

The well-thought-out design and revolutionary technology deliver a perfect sensory experience – whether visual, tactile or culinary.

Our high-quality built-in induction hobs fit seamlessly into modern kitchens. The user-friendly touch panel enables you to control the flexible cooking zones easily and quickly select the desired power level or function. This is not only simple and energy-efficient but also perfect for optimum food preparation. Parallel to this, the JET AIR system ensures that cooking smells seem to disappear almost completely.

Delivering more convenience, more pleasurable cooking and more enjoyment – from the outset.

An overview of the high-end technology

- + User-friendly touch panel with innovative slider controls (1 – 9 levels)
- + High-quality, robust glass surface
- + Efficient energy use thanks to induction technology
- + Red LED lighting
- + Practical automatic heating up
- + Non-slip surface

The new JET AIR System: Turbine power instead of grease filters

How JET AIR separation technology works:

JET AIR separation technology compresses air in a similar way to a jet nozzle. Dirt particles are expelled and collected in a fully washable pan. This revolutionary technology extracts **up to 95%** of all grease and oil particles from the air.

Conventional, less effective grease filters with lower cleaning performance are now a thing of the past. They extract **only 75%** of oil and grease, meeting the criteria for Grease Extraction Level D. JET AIR separation technology achieves Grease Extraction Level A as defined by the German DIN standard. Patented JET AIR separation technology is the only system worldwide which has this innovative technology

Conventional technology with closed fan housing =
No full hygienic cleaning possible!

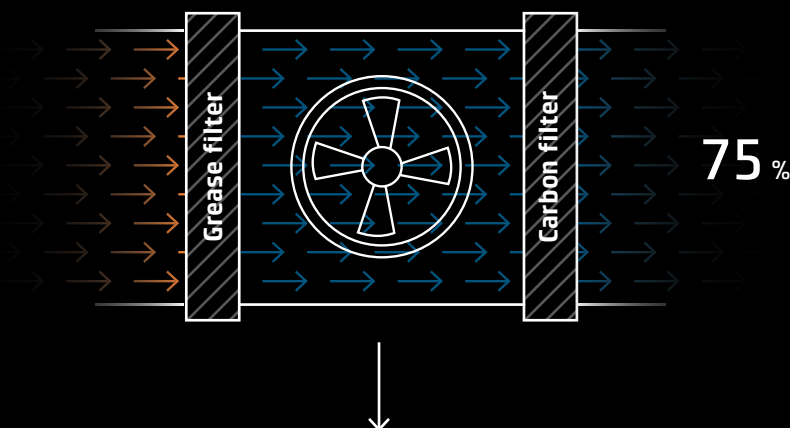

The fan unit cannot be cleaned!



Feel like you never cooked at all!

When you use an air circulation system, air stays in the room making odour filters necessary to bind the odour molecules in the extracted air. CASO Design appliances have an upstream JET AIR system which removes up to

95% of odour molecules before they reach the odour filter, so the integrated carbon fibre mats are hardly needed. These mats remove further odour molecules, leaving air up to 98% clean and making cooking smells seem to disappear almost completely.

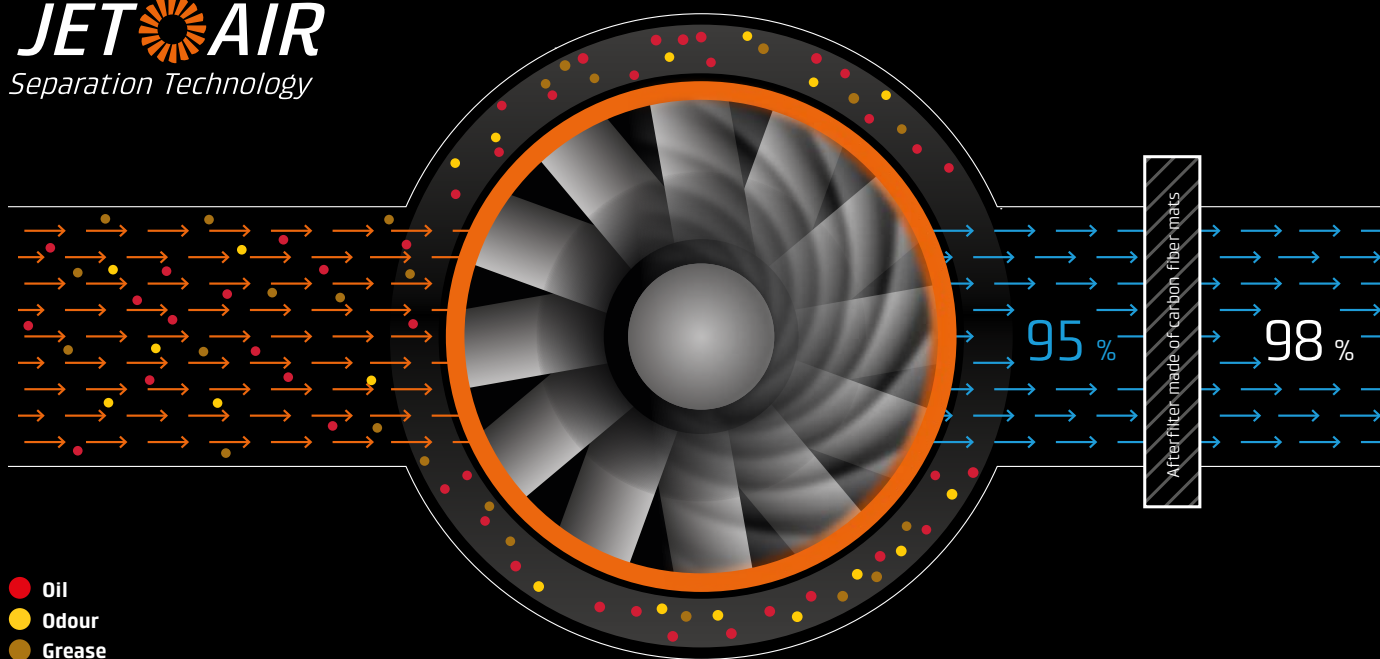



Up to 98% of odours removed from air

- + Clean air, up to 95% grease and oil extraction
- + Carbon fibre mats only need to be replaced every 2.5 years
- + Grease extraction / No sticky residues
- + Consistent extraction performance, no resistance inside the JET AIR system
- + Low maintenance
- + The centrifuge also removes some water vapour
- + No ventilation required
- + Ideal for closed rooms
- + High energy savings (suitable for low-energy homes)
- + No suction loss = permanently consistent performance





The future of air circulation technology

Pure efficiency – the JET AIR system

Simpler, more hygienic, more sustainable. The new CASO Design JET AIR system sets new standards for built-in hobs. No regular filter change is required; it is space-saving and can be fully cleaned for increased hygiene.

100% hygienic

The JET Air system's collecting pan and turbine vane are dishwasher-proof. The carbon fibre mats must only be replaced every two to three years. Conventional appliances have systems which must be fully replaced every 3 to 6 months (depending on the type of odour filter).

Cleaning has never been easier



1. Remove suction nozzle

Just twist the nozzle to remove it from the hob. The drawer and JET AIR system are now accessible.

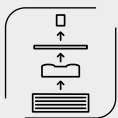

2. Open the drawer and loosen the components

The components can be lifted out one after another, no tools required. Simply take the nozzle duct, lid, turbine insert and collection pan apart.



3. Ready for the dishwasher

All elements are fully dishwasher-proof - including the carbon fibre mats.* A clear advantage over conventional appliances.

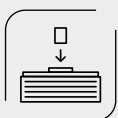
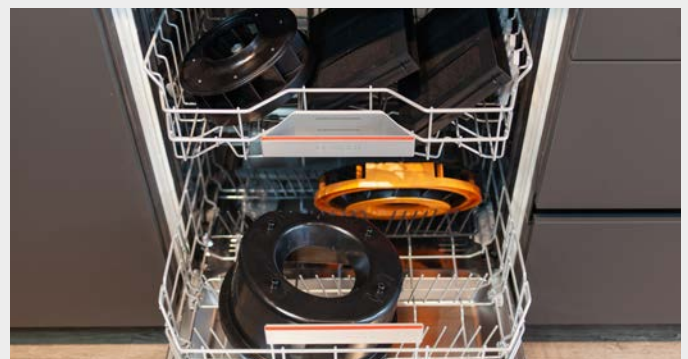

4. Quick insertion

After cleaning the components, simply put all the parts back in the drawer. Easy and efficient – the hob is ready to use again in seconds and is fully functional for your next meal.



* Carbon fibre mats should not be cleaned in the dishwasher every time the system is cleaned.



Great convenience requiring minimal installation effort



Installation video



Operating manual

Easy installation thanks to intelligent technology

Our innovative **plug-in kit** means that installation is child's play. There are just two components in the kit. The induction hob is supplied with a practical runner mechanism which can be used to slot in the **JET AIR system** before it is installed in the kitchen drawer.

The first step is to place the induction hob in the cut-out. The JET AIR system can now be installed at the desired height. To fix the induction hob to the carcass, simply attach it to the brackets it is supplied with. The

JET AIR system can now be slotted into at the runner mechanism. Finally, connect the electronic components - done! The installation video provides detailed installation instructions.

Unlike other extraction systems, no duct has to be installed in other cabinets. Approximately 1/3 of the cabinet volume is required to install the JET AIR system.

The two component set



1. Induction hob



2. JET AIR System

Step 1

Place the hob in the cut-out and fix the components into place.



Step 2

Slot the JET AIR system into the runner mechanism. Finally, connect the electronics.



B6 Air EK

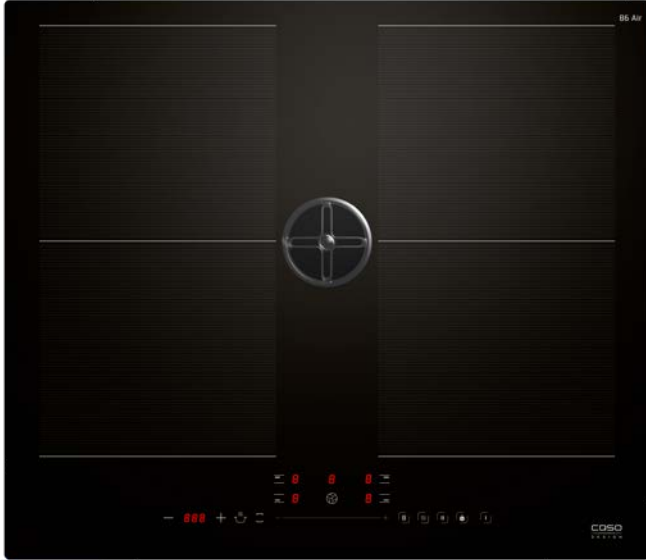

JET AIR
Separation Technology

Surface induction hob with built-in JET AIR air vent

- + Touch control
- + 9 power levels + power boost (for each cooking zone)
- + Slider operation
- + Automatic heating-up
- + Bridge function (front/back)
- + Timer / Timer with acoustic signal
- + Food warming setting
- + Safety switch-off
- + Red LED display
- + Residual heat display
- + Grill function
- + Pause function
- + Recall function
- + Child safety lock

INCLUSIVE
JET AIR Fan core (1×)
(2× UF TH40 included)



Product data

Art. No.:	7255
Power:	4 Surface hob cooking zones 190 × 210 mm, 2,1/3,0 kW Bridge function 3,7 kW
Weight:	10,20 kg
Dimensions:	Frameless, 600 × 55 × 520 mm
Installation:	Flush-mounted or on top
Cut-out dim. (W×D):	574 × 494 mm
Connection values:	Voltage AC 230 V / 2NAC 400 V Power 7,4 kW 120 cm connection cable premounted, 5 × 1,5 mm ²

Spare parts / accessories

Art. No. / Article:	751000009, Umluftfilter UF TH40 (2 pieces), see page 27
---------------------	---

Product Data Fan core LK4

Connection values:	220-240V~ 50/60 Hz
Total output:	Max. 88 W
Noise level:	59 dB(A)
Dimensions (W×H×D):	400 × 200 × 342 mm
Weight:	9 kg
Cable length:	1200 mm

B8 Air EK

JET AIR
Separation Technology



Surface induction hob with built-in JET AIR air vent

- + Touch control
- + 9 power levels + power boost (for each cooking zone)
- + Slider operation
- + Automatic heating-up
- + Bridge function (front/back)
- + Timer / Timer with acoustic signal
- + Food warming setting
- + Safety switch-off
- + Red LED display
- + Residual heat display
- + Grill function
- + Pause function
- + Recall function
- + Child safety lock

INCLUSIVE
JET AIR Fan core (1×)
(2× UF TH40 included)



Product data

Art. No.:	7256
Power:	4 Surface hob cooking zones 190 × 210 mm, 2,1/3,0 kW Bridge function 3,7 kW
Weight:	11,55 Kg
Dimensions:	Frameless, 800 × 55 × 520 mm
Installation:	Flush-mounted or on top
Cut-out dim. (W×D):	774 × 494 mm
Connection values:	Voltage AC 230 V / 2NAC 400 V Power 7,4 kW 120 cm connection cable premounted, 5 × 1,5 mm ²

Spare parts / accessories

Art. No. / Article:	751000009, Umluftfilter UF TH40 (2 pieces), see page 27
---------------------	---

Product Data Fan core LK3

Connection values:	220-240V~ 50/60 Hz
Total output:	Max. 88 W
Noise level:	59 dB(A)
Dimensions (W×H×D):	400 × 200 × 342 mm
Weight:	9 kg
Cable length:	1200 mm

B8 Air EK

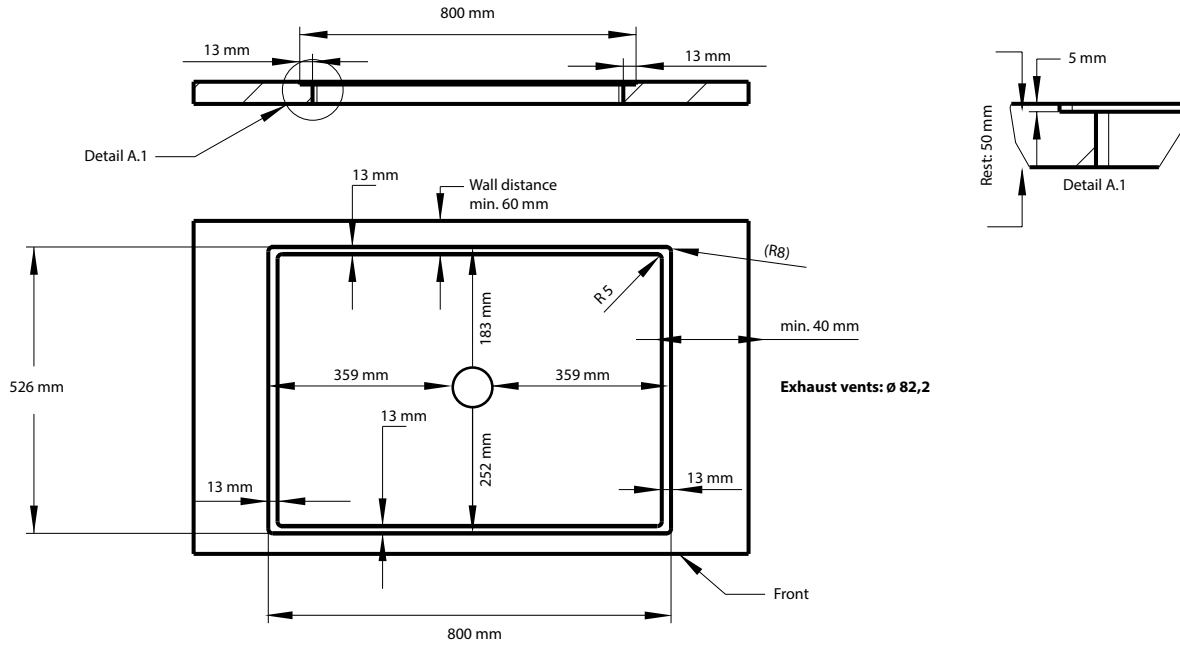

Note: Assembly/installation instructions, operating instructions and all other important documents can be found via this QR code.

Cutout dimensions

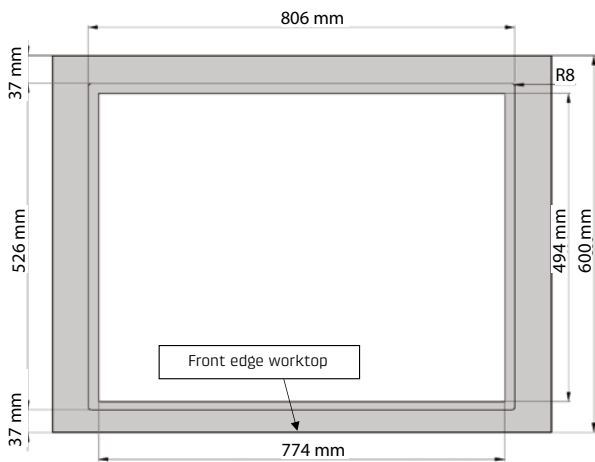

Flush-mounted installation with rebate

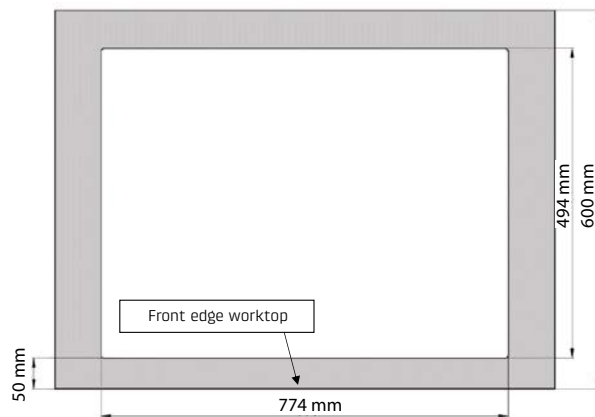

Flush-mounted installation without rebate

Fan core LK4

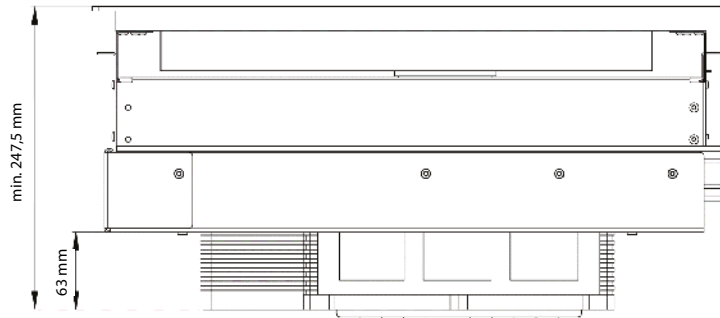

For cupboard carcasses **without** recessed grip profile under the work surface.

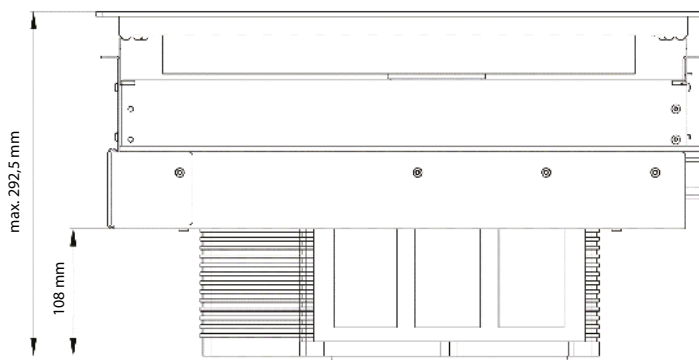

For cupboard carcasses **with** recessed grip profile under the work surface.

The system can be adjusted in 6 intervals of 7.5 mm ranging from min. 247.5 mm to 292.5 mm.



UF TH40



To be inserted into the sides of the JET AIR fan core

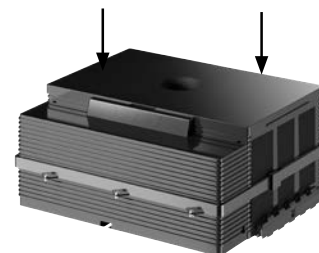

2x carbon fibre mats for filter cassettes

- + Service life up to 2.5 years
- + Can be regenerated 6 times – dishwasher-proof

Product data

Art. No.:	751000009
Weight:	2 × 0,5 kg
Dimensions:	230 × 170 × 32 mm
Applicable for:	B6 Air EK B8 Air EK C9 Air

C9 Air

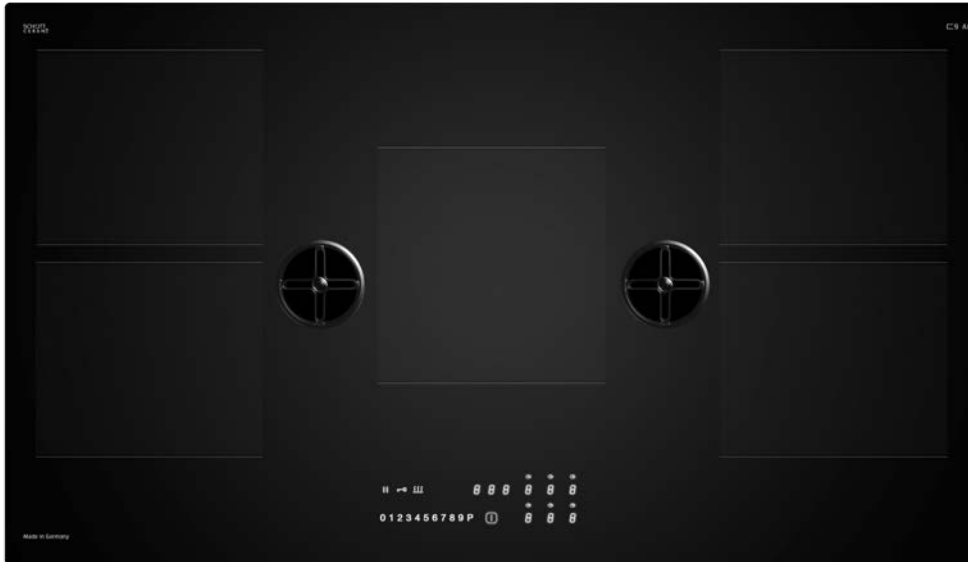

MADE IN GERMANY

SCHOTT
CERAN®

JET AIR
Separation Technology

Surface induction hob with built-in JET AIR air vent

- + Touch control
- + 9 power levels + power boost (for each cooking zone)
- + Sensor control / TC Slim
- + Slider operation
- + Built-in automatic fan control
- + Automatic heating-up
- + Bridge function (front/back)
- + Timer / Timer with acoustic signal
- + Food warming setting
- + Safety switch-off
- + White LED display
- + Residual heat display
- + Grill function
- + Pause function
- + Recall function
- + Key lock
- + Child safety lock (key combination)
- + Automatic fan run-on for 10 minutes
- + Automatic pot detection

INCLUSIVE
JET AIR Fan core (2×)
(each 2× UF TH40 included)



JET BOX, 200 × 422 × 342 mm

Product data

Art. No.:	7232
Power:	5 Surface hob cooking zones 190 × 210 mm, 2,1/3,0 kW Bridge function 3,7 kW
Weight:	14,20 kg
Dimensions:	Frameless, 900 × 55 × 520 mm
Installation:	Flush-mounted or on top
Cutout dim. (B×T):	880 × 490 mm
Connection values:	Voltage AC 230 V / 3NAC 400 V Power 10,4 kW 120 cm connection cable premounted, 5 × 1,5 mm ²

Spare parts / accessories

Art. No. / Article:	751000009, Umluftfilter UF TH40 (2 pieces), see page 25
---------------------	---

Note: The C9 Air induction hob does not have a plug-in system. The installation method is different for this model! See right.

JET AIR Lüfterkern LK4

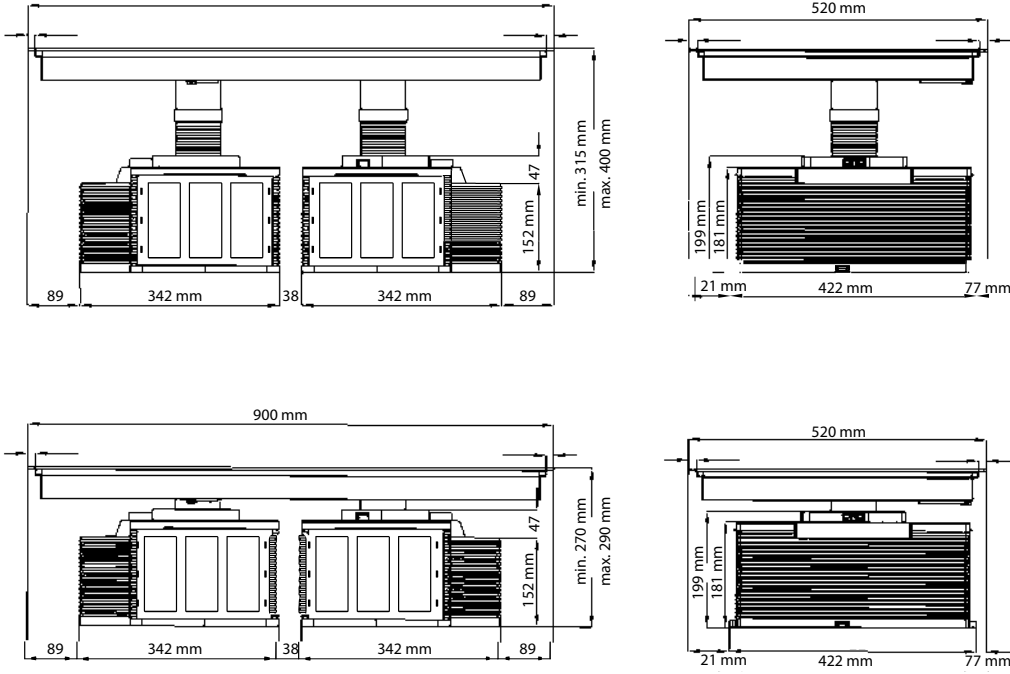

JET AIR
Separation Technology



Installation dimensions with 1 connecting pipe (can be cut to the required height)

Installation dimensions without connecting tube

C9 Air



Note: Assembly/installation instructions, operating instructions and all other important documents can be found via this QR code.

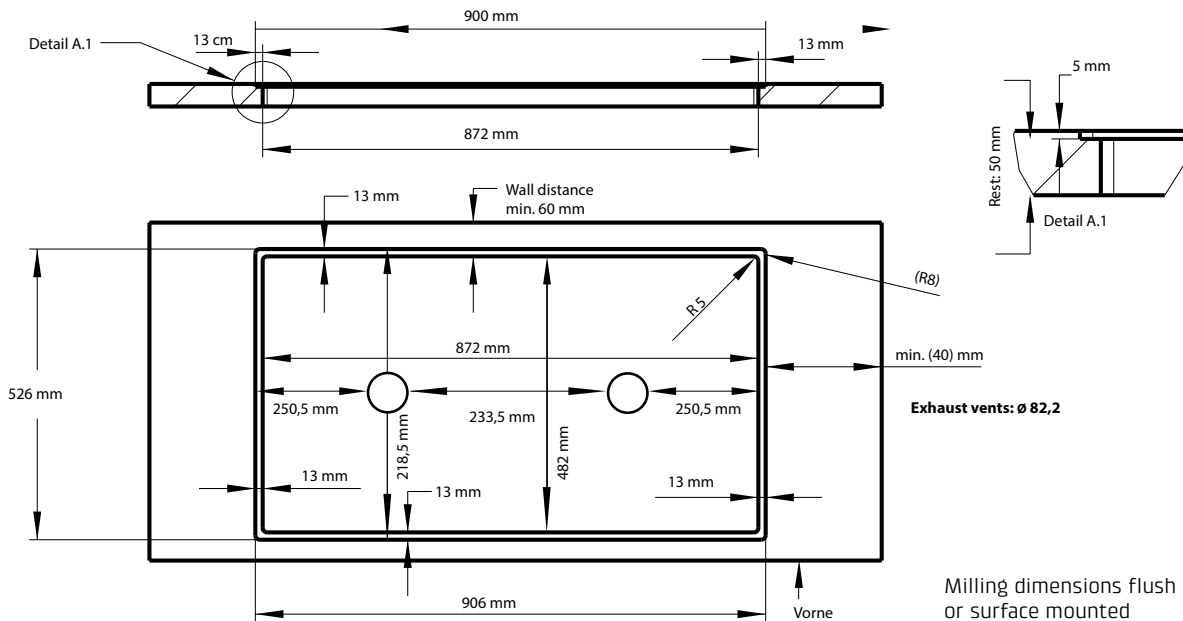

Maximum cooking
enjoyment plus the
greatest possible safety

Modern surface
induction hobs







|| P ||
0 1 2 3 4 5 6 7 8 9 P

⏻ ⏹ ⏸ ⏺ ⏽ ⏾ ⏿

Stylish surface induction hobs

Modern CASO Design induction hobs not only look elegant but also offer maximum cooking enjoyment thanks to their well-designed touch control panels. The innovative slider controls enable you to control the flexible cooking zones easily and quickly select the desired power level or function.

Numerous features such as practical automatic heating-up or the high-performance bridge function make CASO Design induction hobs even more attractive.

Induction technology delivers quick, responsive cooking and is similar to using gas. It makes cooking super clean because nothing can burn.

When it comes to safety, a safety switch-off, built-in child safety lock and key lock make this modern hob a winner.

CASO Design hobs make cooking a unique experience in any kitchen.

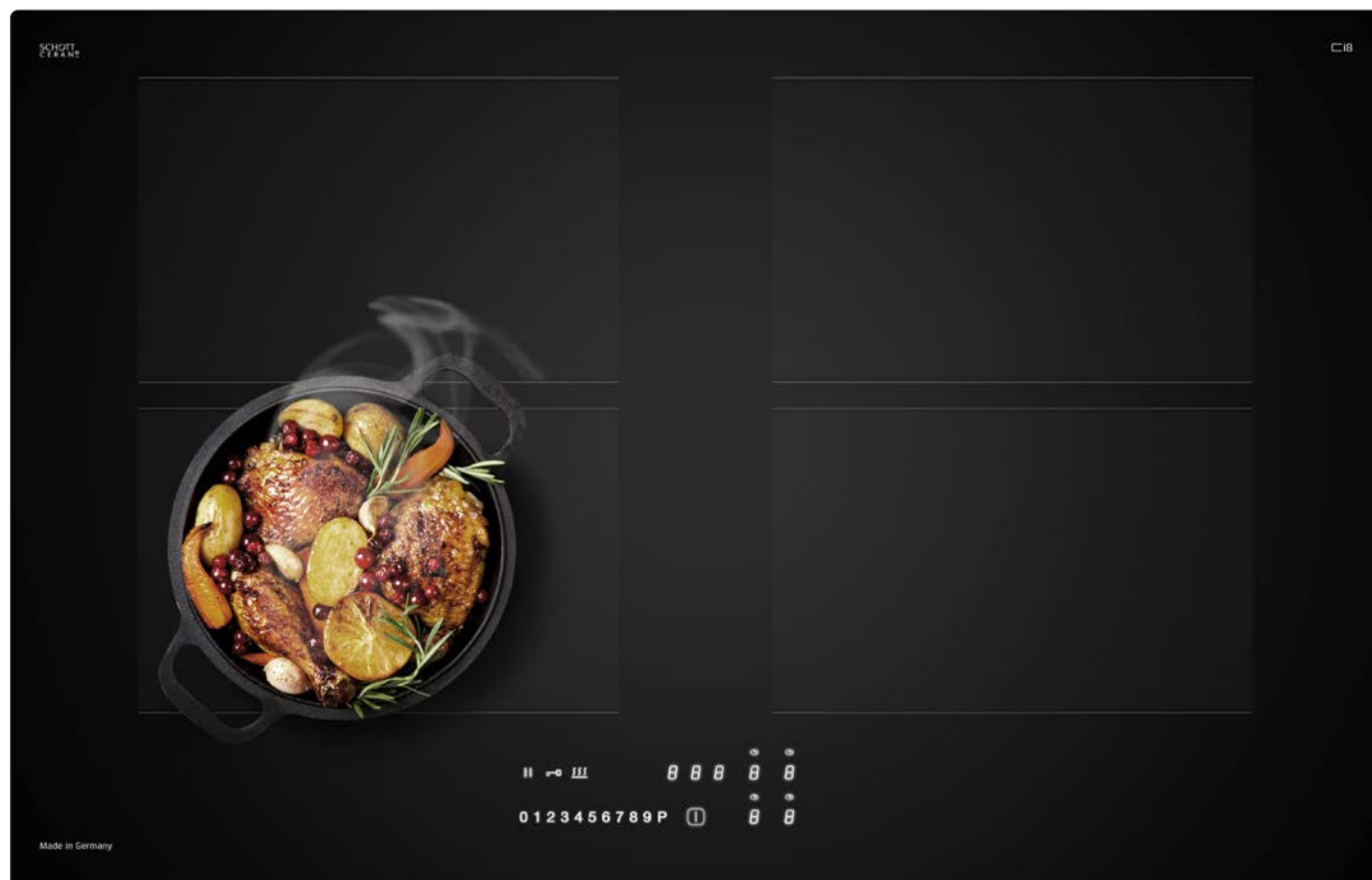

ProAdvanced E1



Single induction hob for built-in built-in or free-standing use

- + Versatile uses, e.g. in small and outdoor kitchens, in tiny houses, in camper vans and holiday homes, for breakfast buffets, on balconies and patios, etc.
- + Also ideal as an additional food warming plate
- + Particularly sustainable thanks to fast, energy- and money-saving cooking
- + Elegant, timeless black design
- + For induction cookware with a base diameter of 12-24 cm
- + Quickly ready for use thanks to automatic pot recognition and powerful 2100 watt performance
- + **12 power levels for precise results**
- + **12 Temperature levels**
- + **Temperature adjustable from 60 - 240 °C**
 - 60 – 100 °C in 10 °C intervals
 - 100 – 240 °C in 20 °C intervals
- + Practical, optional timer function from 1 – 180 mins
- + Black all-glass surface with touch operating panel for easy cleaning
- + Digital screen with red LED display
- + Incl. sealing strip for built-in installation and a magnet to recognise suitable cookware
- + Safe thanks to overheating protection

Product data

Art. No.:	3043
Power:	2100 Watt
Weight:	3,46 kg
Dimensions:	Surface: 290 x 360 mm Cut-Out: 270 x 340 mm
Connection values:	220-240 V, 50/60 Hz

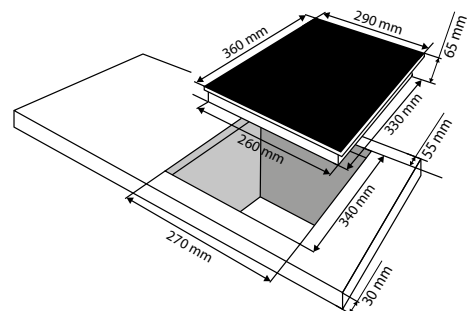

Master E 2

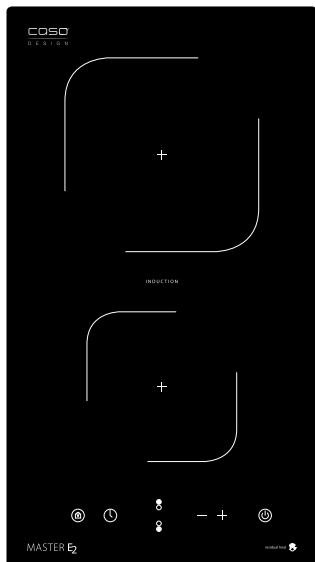

Double induction build-in hob

- + Induction cooker with 2 zones with 3500 watt (1500 watt & 2000 watt)
- + All-glass Schott Ceran® surface from environmentally friendly Ceran Suprema®
- + Sensor-touch-operation and big digital display
- + Timer, power levels and temperature individually adjustable
- + 9 power levels per cooking field
- + Timer function 1 - 99 minutes in 1-minute-intervalls
- + Lock-function (setting protection / child safety lock)
- + Safe thanks to automatic pot detection and overheating protection
- + Automatic switch-off when not in use
- + Very easy cleaning

Product data

Art. No.:	3041
Power:	3500 Watt (1500 & 2000 Watt)
Weight:	5,2 kg
Dimensions:	Surface: 290 x 60 x 520 mm Cut-Out: 268 x 500 mm
Connection values:	230 V, 50 Hz

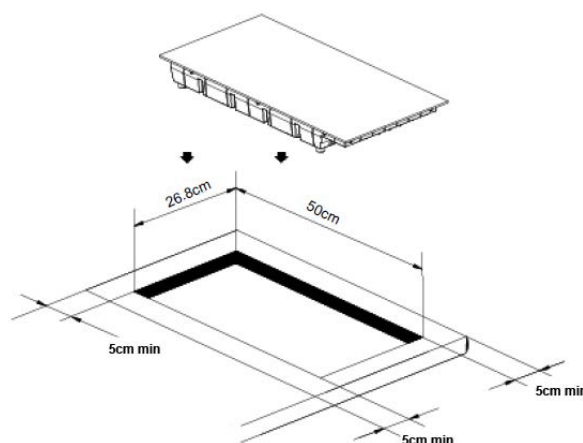

Note: Assembly/installation instructions, operating instructions and all other important documents can be found via this QR code.



Ci 6

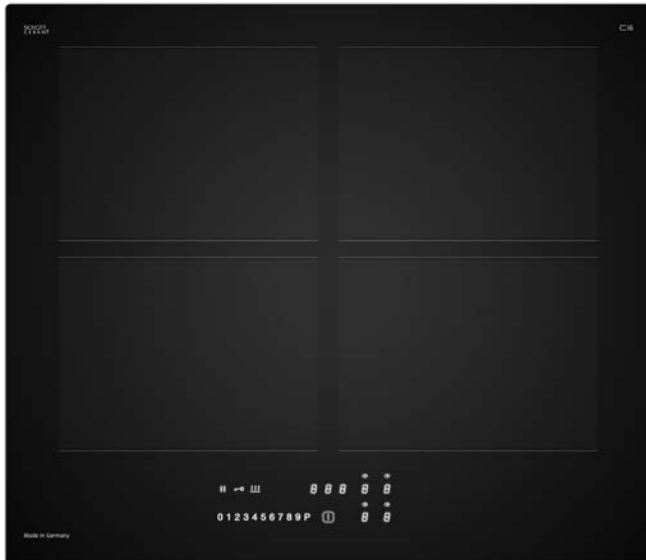

MADE IN GERMANY

SCHOTT
CERAN®

Surface induction hob

- + Touch control
- + Sensor control / TC Slim
- + **Slider operation**
- + **Automatic heating-up**
- + **power level + power boost**
(for each cooking zone)
- + **Bridge function (front/back)**
- + Timer / Timer with acoustic signal
- + Food warming setting
- + Safety switch-off
- + White LED display
- + Residual heat display
- + Grill function
- + Pause function
- + Recall function
- + **Key lock**
- + Child safety lock (key combination)
- + Automatic pot detection

Product data

Art. No.:	7227
Power:	4 hob cooking zones 190 × 210 mm, 2,1/3,0 kW Bridge function 3,7 kW
Weight:	9,45 kg
Dimensions:	Frameless, 600 × 55 × 520 mm
Installation:	Flush-mounted or on top
Cut-Out dim. (W×D):	562 × 482 mm
Connection values:	Voltage AC 230 V / 2NAC 400 V Power 7,4 KW 120 cm connection cable premounted, 5 × 1,5 mm ²

Ci 8

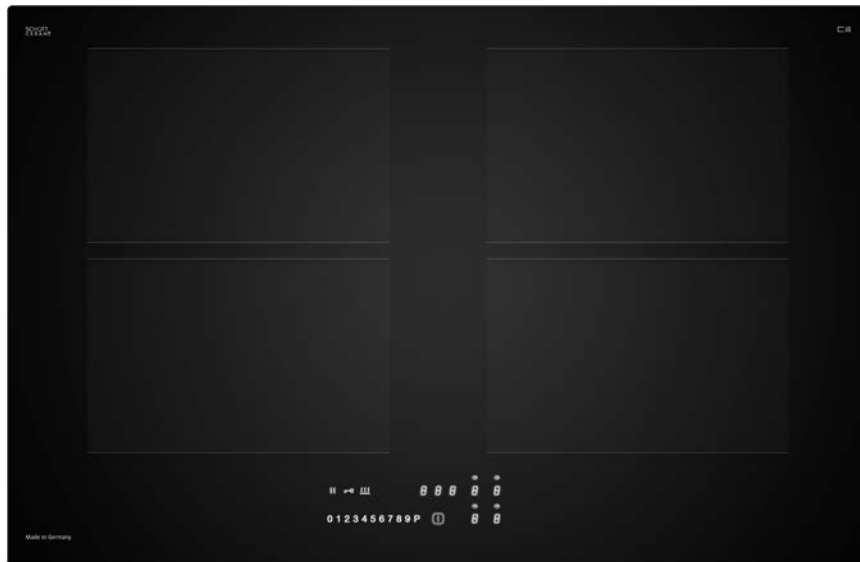

Surface induction hob

- + Touch control
- + Sensor control / TC Slim
- + **Slider operation**
- + **Automatic heating-up**
- + **power level + power boost**
(for each cooking zone)
- + **Bridge function (front/back)**
- + Timer / Timer with acoustic signal
- + Food warming setting
- + Safety switch-off
- + White LED display
- + Residual heat display
- + Grill function
- + Pause function
- + Recall function
- + **Key lock**
- + Child safety lock (key combination)
- + Automatic pot detection

Product data

Art. No.:	7228
Power:	4 hob cooking zones 190 × 210 mm, 2,1/3,0 kW Bridge function 3,7 kW
Weight:	10,85 kg
Dimensions:	Frameless, 800 × 55 × 520 mm
Installation:	Flush-mounted or on top
Cut-Out dim. (W×D):	745 × 482 mm
Connection values:	Voltage AC 230 V / 2NAC 400 V Power 7,4 KW 120 cm connection cable premounted, 5 × 1,5 mm ²

Ci 9

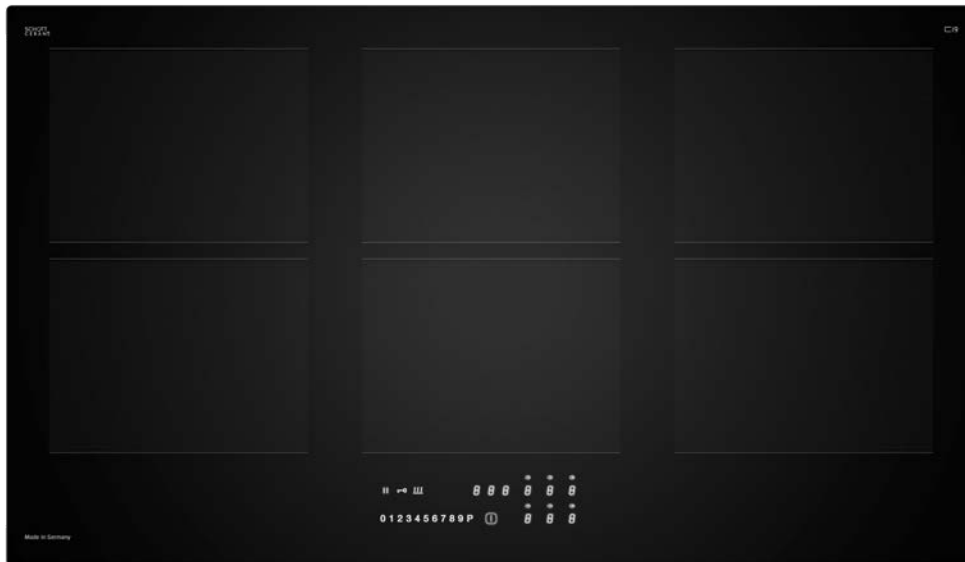

MADE IN GERMANY

SCHOTT
CERAN®

Surface induction hob

- + Touch control
- + Sensor control / TC Slim
- + **Slider operation**
- + **Automatic heating-up**
- + **power level + power boost**
(for each cooking zone)
- + **Bridge function (front/back)**
- + Timer / Timer with acoustic signal
- + Food warming setting
- + Safety switch-off
- + White LED display
- + Residual heat display
- + Grill function
- + Pause function
- + Recall function
- + **Key lock**
- + Child safety lock (key combination)
- + Automatic pot detection

Product data

Art. No.:	7229
Power:	6 hob cooking zones 190 × 210 mm, 2,1/3,0 kW Bridge function 3,7 kW
Weight:	14,10 kg
Dimensions:	Frameless, 900 × 55 × 520 mm
Installation:	Flush-mounted or on top
Cut-Out dim. (W×D):	872 × 482 mm
Connection values:	Voltage AC 230 V / 3NAC 400 V Power 11,1 KW 120 cm connection cable premounted, 5 × 1,5 mm ²

Ci 6

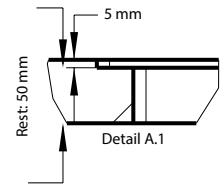
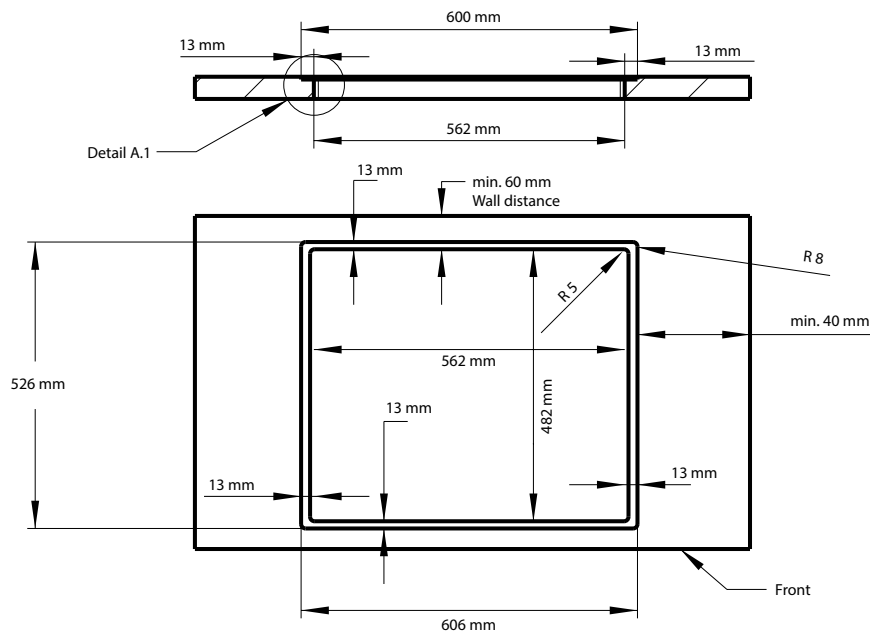

Milling dimensions flush or surface mounted

Ci 8

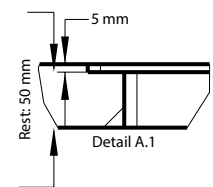
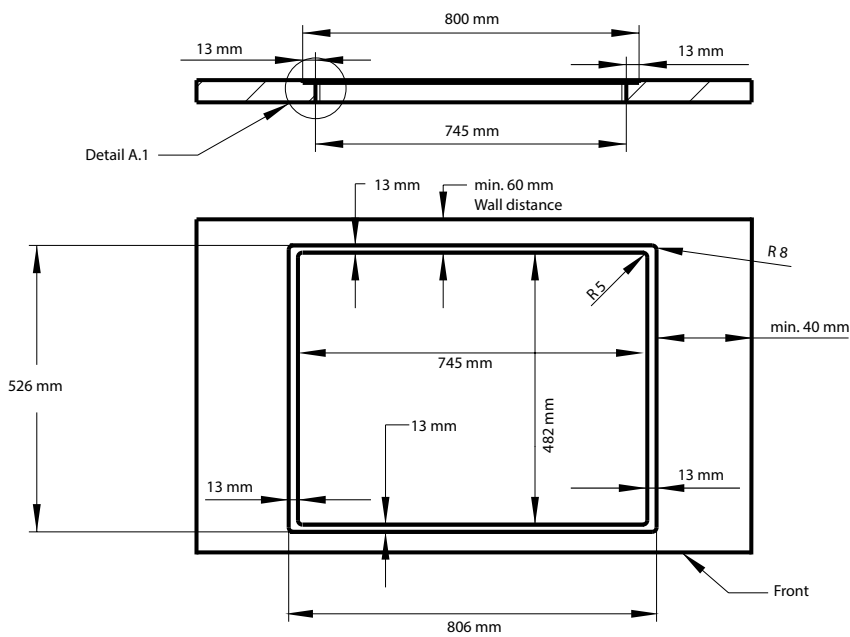

Milling dimensions flush or surface mounted

Ci 9

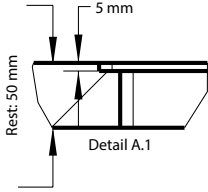
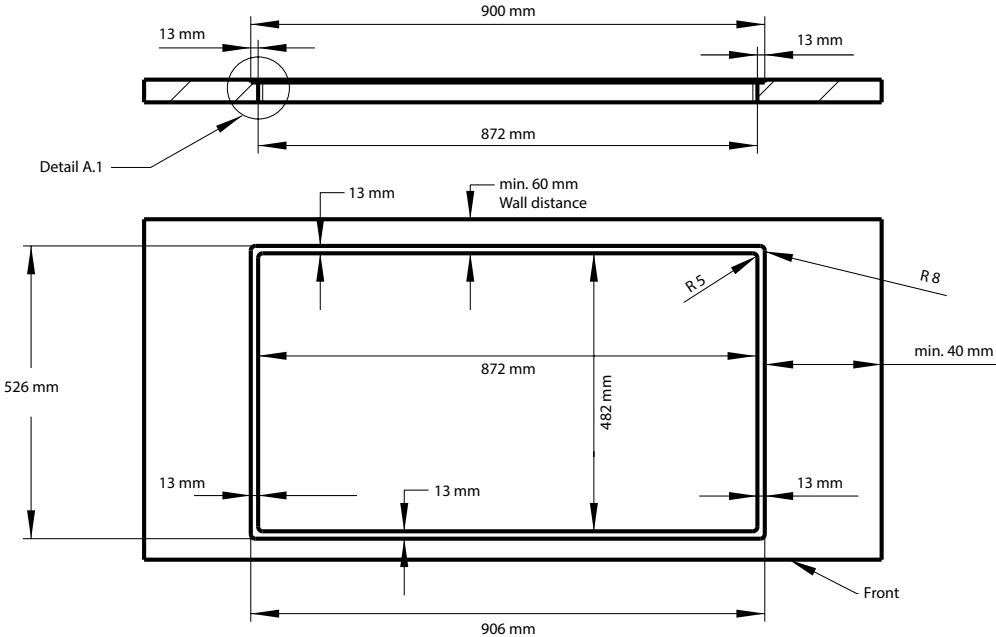

Milling dimensions flush or surface mounted



Note: Assembly/installation instructions, operating instructions and all other important documents can be found via this QR code.

ProTaste P4



Induktions-Topfset (4er-Set)

- + Design pot set with four different pots made of high-quality, matt 18/10 stainless steel
- + Thanks to innovative steam outlet optimal for downdraft systems and trough fans - vapors, odors and grease are directed into the induction hob in a controlled manner
- + No power stage of the fan necessary - noise level decreases
 - Cooking with closed lid - saves time and energy
 - Optimal cooking at any pot height
 - Easy pouring with closed lid
 - High-quality glass lid with stainless steel rim, silicone seal and steam outlet
 - No leakage of dripping liquids, no trickling into the ventilation
- + Internal measuring scale
- + Solid pot bottoms for optimal heat distribution
- + Dishwasher safe
- + Scope of delivery:
 - Pot Ø 16 x 9 cm (approx. 1.7 l capacity) + Glass lid
 - Pot Ø 20 x 11 cm (approx. 3.4 l capacity) + Glass lid
 - Pot Ø 24 x 13 cm (approx. 6,0 l capacity) + glass lid
 - Pot Ø 28 x 8 cm (approx. 4.8 l capacity) + glass lid

Product data

Art. No.:

810

Dimensions:

- Topf Ø 16 x 9 cm (ca. 1,7 L capacity)
- Topf Ø 20 x 11 cm (ca. 3,4 L capacity)
- Topf Ø 24 x 13 cm (ca. 6,0 L capacity)
- Topf Ø 28 x 8 cm (ca. 4,8 L capacity)



Stylish and precise

Built-in wine coolers with
compressor technology







Perfect chilling thanks to innovative technology

CASO Design exclusive wine coolers meet all aspects of a wide range of requirements. Our WineDeluxe series has a smart black design with an elegant glass front. These high-quality wine refrigerators have smooth-running compressors which ensure the gentle atmosphere your wine needs for optimum aging.

Control from almost everywhere. The integrated smart control system enables you to individually regulate the two separate temperature zones from 5 to 20 °C. Allowing your wine to maintain its typical character.

You're looking for even more style? Then simply turn on the atmospheric ambient LED strip lighting to showcase your wine in a new light. The wooden storage shelves are fitted with practical telescopic runners which enable you to remove your wine bottles as safely as possible.

Soft-close hinges and a push-to-open mechanism make opening the door child's play. Our top priority is always user convenience.

See for yourself. CASO Design offers you the perfect space for your best vintages.



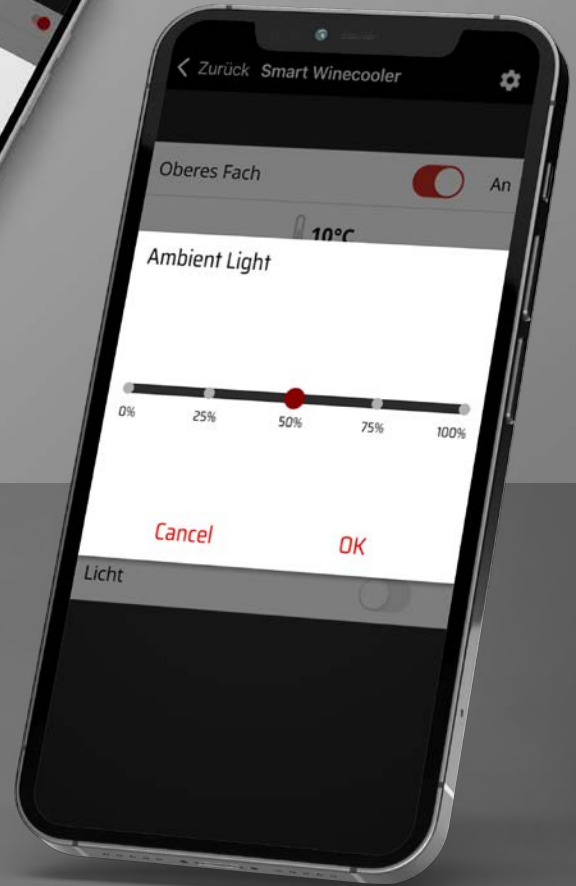

Smart control, perfect chilling

The CASO Control App

The CASO control app enables you to easily control CASO Design products from wherever you are using your smartphone or tablet. When setting your CASO Design wine cabinet the app can now also save you up to 15 % energy - or even more! The latest version includes a Smart ECO mode which enables you to select the most energy-saving operation mode for your CASO Design wine cabinet.

When set to the Smart ECO mode the cooling zone will turn off for the pre-set time period – for example, the 10 °C white wine cooling zone turns off from midnight to 8.00 am. During the selected “resting time” the temperature in the zone will gradually increase by approx. 3 °C to 13 °C. At 8.00 am the compressor turns back on, reaching the desired drinking temperature around 1 to 1.5 hours later. Depending on the time slot you choose, this will generate an energy saving of approx. 15% or more. It goes without saying that you can also use this function when you are on holiday or, if you are a caterer, on days when your business is closed. Simply smart energy saving – CASO Design style.

An overview of the app:

- + Control and manage your appliance wherever you are
- + The app technology is based on a closed, secure, independent system in Germany
- + Smart ECO mode: Use the app to control energy consumption via an individual time slot/ interval, saving energy and money
- + FineTemp - control the temperature of sous vide elements
- + Automation of technical functions
- + Direct contact to support via the integrated feedback function



WineDeluxe WD 17

17 bottles	Wi-Fi module	Push-to-open	Soft-close hinges	One temperature zone	Safety glass with UV filter	Sensor-Touch Display	Ambient LED strips
Wood storage shelves	Telescopic ball bearing runners	Activated carbon filter	37 dB				



Design built-in wine cooler with compressor technology

- + Design built-in wine cooler to store up to 17 bottles (up to 76 mm Ø and 310 mm height)
- + In combination with the CASO app, the integrated **Wi-Fi module** enables you to control the appliance from almost everywhere
- + Handleless, elegant **push-to-open** door mechanism
- + **Soft-close** hinges for gentle closing
- + Smooth-running compressor guarantees gentle, vibration-free wine storage
- + One temperature zones individually electronically adjustable from 5 to 20 °C (41 to 68 °F)**
- + Active ventilation for even temperature distribution
- + **3-layer insulated glass with UV filter** for optimum aroma protection
- + Door alarm signals any loss of temperature when the door is open
- + Elegant **sensor touch screen**
- + **LED temperature display** for each cooling zone
- + White **ambient LED strip lighting** on the sides can be set at 4 light intensity levels – Level 1 (25%), Level 2 (50%), Level 3 (75%) and Level 4 (100%)
- + Simple removal of wine bottles thanks to **wooden storage shelves** with built-in **telescopic ball bearing runners**
- + Activated carbon filter for optimum air quality
- + Noise level 36 dB
- + **Door hinges can be fitted on the left or the right**

Product data

Art. No.:	7712	
Power:	120 W	
Weight:	33 kg	
Dimensions (W×H×D):	595 × 455 × 575 mm	
Installation:	For every 45 niche height, door hinge changeable	max. bottle length top: 370 mm bottom: 320 mm
Connection values:	220-240V/50-60Hz	



* The achievable value in the interior cannot be higher than the ambient temperature at the installation site.

WineDeluxe WD 24

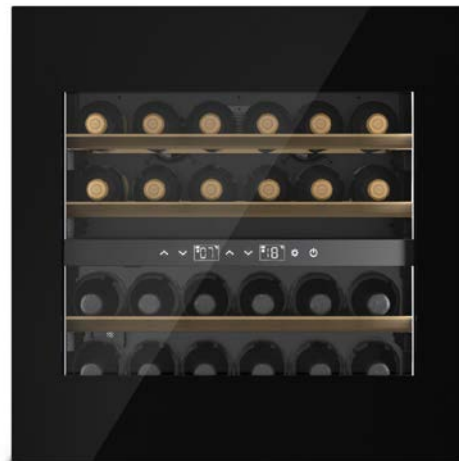
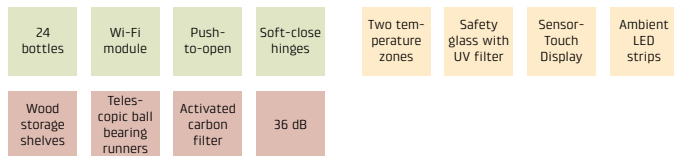

Design built-in wine cooler with compressor technology

- + Design built-in wine cooler to store up to 24 bottles (up to 76 mm Ø)
- + In combination with the CASO app, the integrated **Wi-Fi module** enables you to control the appliance from almost everywhere
- + Handleless, elegant **push-to-open** door mechanism
- + **Soft-close** hinges for gentle closing
- + Smooth-running compressor guarantees gentle, vibration-free wine storage
- + Two temperature zones* individually electronically adjustable from 5 to 20 °C (41 to 68 °F)**
- + Active ventilation for even temperature distribution
- + **3-layer insulated glass with UV filter** for optimum aroma protection
- + Door alarm signals any loss of temperature when the door is open
- + **Sensor touch screen** for both zones
- + LED temperature display for each cooling zone
- + White **ambient LED strip lighting** on the sides can be set at 4 light intensity levels – Level 1 (25%), Level 2 (50%), Level 3 (75%) and Level 4 (100%)
- + Simple removal of wine bottles thanks to **wooden storage shelves** with built-in **telescopic ball bearing runners**
- + Activated carbon filter for optimum air quality
- + Noise level 36 dB
- + **Door hinges can be fitted on the left or the right**

Product data

Art. No.:	7713	
Power:	120 W	
Weight:	41 kg	
Dimensions (W×H×D):	595 × 595 × 575 mm	
Installation:	For every 60 niche height, door hinge changeable	max. bottle length top: 370 mm bottom: 320 mm
Connection values:	220-240V/50-60Hz	



* Cascading control system (the upper zone must be colder than or the same as than the lower one)

** The temperature which can be achieved inside the fridge should not exceed the ambient temperature in the room in which it is installed

WineDeluxe WD 41

41 bottles	Wi-Fi module	Push-to-open	Soft-close hinges	Two temperature zones	Safety glass with UV filter	Sensor-Touch Display	Ambient LED strips
Wood storage shelves	Telescopic ball bearing runners	Activated carbon filter	37 dB				



Design built-in wine cooler with compressor technology

- + Design built-in wine cooler to store up to 41 bottles (up to 76 mm Ø)
- + In combination with the CASO app, the integrated **Wi-Fi module** enables you to control the appliance from almost everywhere
- + Handleless, elegant **push-to-open** door mechanism
- + **Soft-close** hinges for gentle closing
- + Smooth-running compressor guarantees gentle, vibration-free wine storage
- + Two temperature zones* individually electronically adjustable from 5 to 20 °C (41 to 68 °F)**
- + Active ventilation for even temperature distribution
- + **3-layer insulated glass with UV filter** for optimum aroma protection
- + Door alarm signals any loss of temperature when the door is open
- + **Sensor touch screen** for both zones
- + LED temperature display for each cooling zone
- + White **ambient LED strip lighting** on the sides can be set at 4 light intensity levels – Level 1 (25%), Level 2 (50%), Level 3 (75%) and Level 4 (100%)
- + Simple removal of wine bottles thanks to **wooden storage shelves** with built-in **telescopic ball bearing runners**
- + Incl. metal rack to display bottles
- + Activated carbon filter for optimum air quality
- + Noise level 37 dB
- + **Door hinges can be fitted on the left or the right**

Product data

Art. No.:	7714	
Power:	120 W	
Weight:	55 kg	
Dimensions (W×H×D):	595 × 891,5 × 575 mm	
Installation:	For every 88 niche height, door hinge changeable	max. bottle length top: 370 mm bottom: 320 mm
Connection values:	220-240V/50-60Hz	



* Cascading control system (the upper zone must be colder than or the same as than the lower one)

** The temperature which can be achieved inside the fridge should not exceed the ambient temperature in the room in which it is installed

WineDeluxe WD 60

60 bottles	Wi-Fi module	Push-to-open	Soft-close hinges	Two temperature zones	Safety glass with UV filter	Sensor-Touch Display	Ambient LED strips
Wood storage shelves	Telescopic ball bearing runners	Activated carbon filter	38 dB				

Design built-in wine cooler with compressor technology

- + Design built-in wine cooler to store up to 60 bottles (up to 76 mm Ø)
- + In combination with the CASO app, the integrated **Wi-Fi module** enables you to control the appliance from almost everywhere
- + Handleless, elegant **push-to-open** door mechanism
- + **Soft-close** hinges for gentle closing
- + Smooth-running compressor guarantees gentle, vibration-free wine storage
- + Two temperature zones* individually electronically adjustable from 5 to 20 °C (41 to 68 °F)**
- + Active ventilation for even temperature distribution
- + **3-layer insulated glass with UV filter** for optimum aroma protection
- + Door alarm signals any loss of temperature when the door is open
- + **Sensor touch screen** for both zones
- + LED temperature display for each cooling zone
- + White **ambient LED strip lighting** on the sides can be set at 4 light intensity levels – Level 1 (25%), Level 2 (50%), Level 3 (75%) and Level 4 (100%)
- + Simple removal of wine bottles thanks to **wooden storage shelves** with built-in **telescopic ball bearing runners**
- + Incl. metal rack to display bottles
- + Activated carbon filter for optimum air quality
- + Noise level 38 dB
- + **Door hinges can be fitted on the left or the right**

Product data

Art. No.:	7715	
Power:	120 W	
Weight:	71 kg	
Dimensions (W×H×D):	595 × 1238 × 575 mm	
Installation:	For every 122 niche height, door hinge changeable	max. bottle length top: 365 mm bottom 315 mm
Connection values:	220-240V/50-60Hz	



* Cascading control system (the upper zone must be colder than or the same as than the lower one)

** The temperature which can be achieved inside the fridge should not exceed the ambient temperature in the room in which it is installed

WineDeluxe WD 96

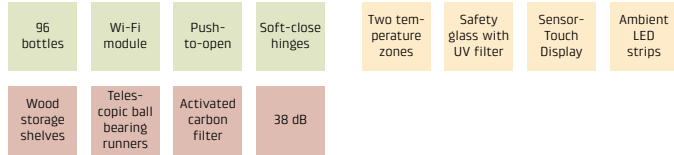

Design built-in wine cooler with compressor technology

- + Design built-in wine cooler to store up to 96 bottles (up to 76 mm Ø)
- + In combination with the CASO app, the integrated **Wi-Fi module** enables you to control the appliance from almost everywhere
- + Handleless, elegant **push-to-open** door mechanism
- + **Soft-close** hinges for gentle closing
- + Smooth-running compressor guarantees gentle, vibration-free wine storage
- + Two temperature zones* individually electronically adjustable from 5 to 20 °C (41 to 68 °F)**
- + Active ventilation for even temperature distribution
- + **3-layer insulated glass with UV filter** for optimum aroma protection
- + Door alarm signals any loss of temperature when the door is open
- + **Sensor touch screen** for both zones
- + LED temperature display for each cooling zone
- + White **ambient LED strip lighting** on the sides can be set at 4 light intensity levels – Level 1 (25%), Level 2 (50%), Level 3 (75%) and Level 4 (100%)
- + Simple removal of wine bottles thanks to **wooden storage shelves** with built-in **telescopic ball bearing runners**
- + Incl. metal rack to display bottles
- + Activated carbon filter for optimum air quality
- + Noise level 38 dB
- + **Door hinges can be fitted on the left or the right**



Product data

Art. No.:	7716	
Power:	120 W	
Weight:	95 kg	
Dimensions (W×H×D):	595 × 1789,5 × 575 mm	
Installation:	For every 178 niche height, door hinge changeable	max. bottle length top: 365 mm bottom 315 mm
Connection values:	220-240V/50-60Hz	



* Cascading control system (the upper zone must be colder than or the same as than the lower one)

** The temperature which can be achieved inside the fridge should not exceed the ambient temperature in the room in which it is installed

Design built-in wine cooler with compressor technology

WineDeluxe WDU 18

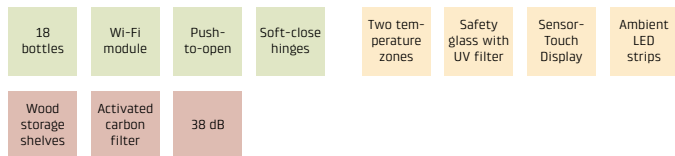

Design undercounter wine cooler with compressor technology

- + Design undercounter wine cooler to store up to 18 bottles (up to 76 mm Ø)
- + In combination with the CASO app, the integrated **Wi-Fi module** enables you to control the appliance from almost everywhere
- + Handleless, elegant **push-to-open** door mechanism
- + **Soft-close** hinges for gentle closing
- + Smooth-running compressor guarantees gentle, vibration-free wine storage
- + Two temperature zones* individually electronically adjustable from 5 to 20 °C (41 to 68 °F)**
- + Active ventilation for even temperature distribution
- + **3-layer insulated glass with UV filter** for optimum aroma protection
- + Door alarm signals any loss of temperature when the door is open
- + **Sensor touch screen** for both zones
- + LED temperature display for each cooling zone
- + White **ambient LED strip lighting** on the sides can be set at 4 light intensity levels – Level 1 (25%), Level 2 (50%), Level 3 (75%) and Level 4 (100%)
- + Simple removal of wine bottles thanks to **wooden storage shelves**
- + Activated carbon filter for optimum air quality
- + Noise level 38 dB
- + **Door hinges can be fitted on the left or the right**

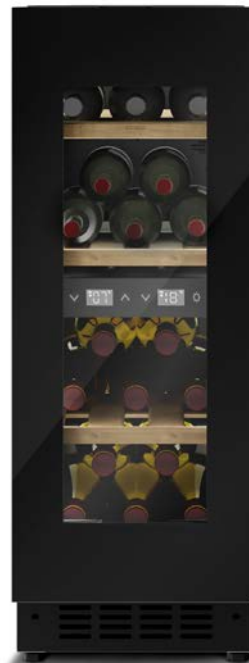

Spare parts / accessories

Art. No. / Article: 7709, Compensation panel 30 niche width (5,5 x 29,5 cm)



Product data

Art. No.: 7719
Power: 120 W
Dimensions (W×H×D): 295 × 818 × 562 mm
Installation: For every 30 niche width, door hinge changeable
Connection values: 220-240V/50Hz

max. bottle length
top: 400 mm
lowest: 310 mm



* Cascading control system (the upper zone must be colder than or the same as than the lower one)

** The temperature which can be achieved inside the fridge should not exceed the ambient temperature in the room in which it is installed

WineDeluxe WDU 36

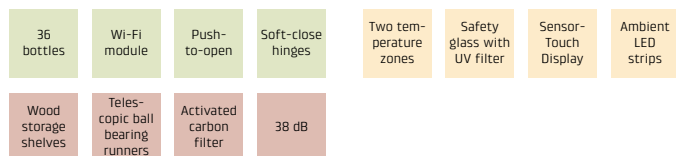

Design undercounter wine cooler with compressor technology

- + Design undercounter wine cooler to store up to 36 bottles (up to 76 mm Ø)
- + In combination with the CASO app, the integrated **Wi-Fi module** enables you to control the appliance from almost everywhere
- + Handleless, elegant **push-to-open** door mechanism
- + **Soft-close** hinges for gentle closing
- + Smooth-running compressor guarantees gentle, vibration-free wine storage
- + Two temperature zones* individually electronically adjustable from 5 to 20 °C (41 to 68 °F)**
- + Active ventilation for even temperature distribution
- + **3-layer insulated glass with UV filter** for optimum aroma protection
- + Door alarm signals any loss of temperature when the door is open
- + **Sensor touch screen** for both zones
- + LED temperature display for each cooling zone
- + White **ambient LED strip lighting** on the sides can be set at 4 light intensity levels – Level 1 (25%), Level 2 (50%), Level 3 (75%) and Level 4 (100%)
- + Simple removal of wine bottles thanks to **wooden storage shelves** with built-in **telescopic ball bearing runners**
- + Incl. metal rack to display bottles
- + Activated carbon filter for optimum air quality
- + Noise level 38 dB
- + **Door hinges can be fitted on the left or the right**



- + Can be used from 100 mm plinth height with 720 mm carcass (external dimension)

Spare parts / accessories

Art. No. / Article: 7707, Compensation panel for 780 mm carcasses (5,5 x 59,5 cm)



Product data

Art. No.: 7717
 Power: 120 W
 Weight: 54,5 kg
 Dimensions (W×H×D): 595 × 819 × 575 mm
 Installation: For every 60 niche width, door hinge changeable
 Connection values: 220-240V/50Hz

max. bottle length
 top: 420 mm
 lowest: 330 mm



* Cascading control system (the upper zone must be colder than or the same as than the lower one)

** The temperature which can be achieved inside the fridge should not exceed the ambient temperature in the room in which it is installed

WineChef Duo 122 Black



Design (rebuildable) wine cooler with compressor technology

- + High-quality wine cooler with compressor technology
- + Storage of up to 122 wine bottles
- + **Two separate temperature zones**, individually adjustable for the right and left side
- + Sensor-touch display with LED temperature indicators for both zones and quick-select options for preferred settings
- + Temperature range electronically adjustable from 5 - 20 °C (41 - 68 °F)*
- + **Active fan** ensures consistent temperature distribution
- + Quiet-running compressor: Provides the tranquility your wine needs
- + 3-layer insulating safety glass with UV filter for optimal aroma protection
- + Can be used **freestanding or built-in** thanks to cooling over the appliance base
- + Equipped with 13 wave-shaped wire shelves and 4 metal shelves
- + Side-mounted interior LED lighting beautifully showcases your wine
- + Timeless black design with elegant tinted glass front

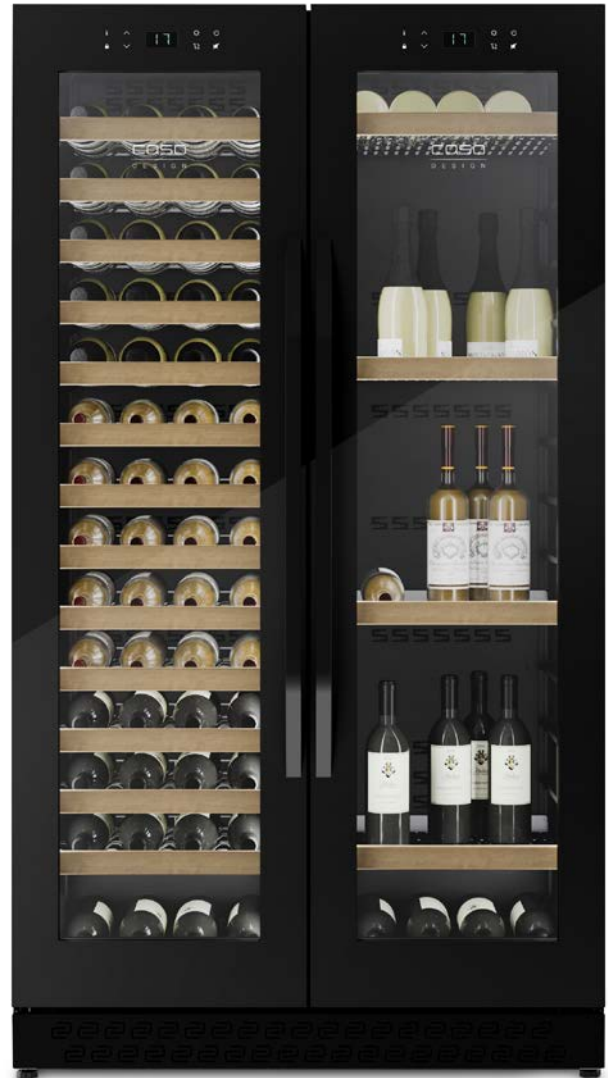

Installation tip: Set right and left side panel to carcass depth to equalise the opening angle of the door

Product data

Art. No.:	674	
Power:	160 W	max. bottle length
Weight:	108 kg	for max. content
Dimensions (W×H×D):	890 × 1619 × 605 mm	(122 pieces):
Connection values:	220-240V/50Hz	300 mm



* The temperature which can be achieved inside the fridge should not exceed the ambient temperature in the room in which it is installed



WineDeluxe WD 17

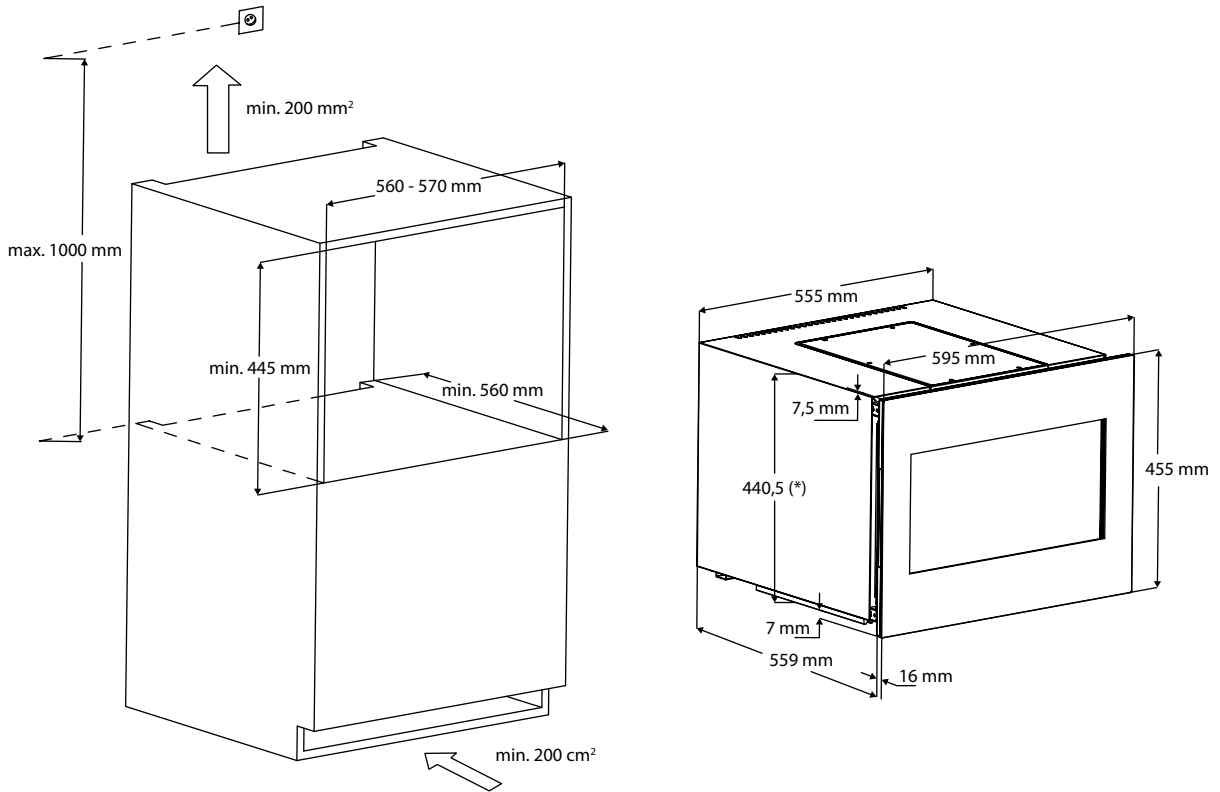

WineDeluxe WD 24

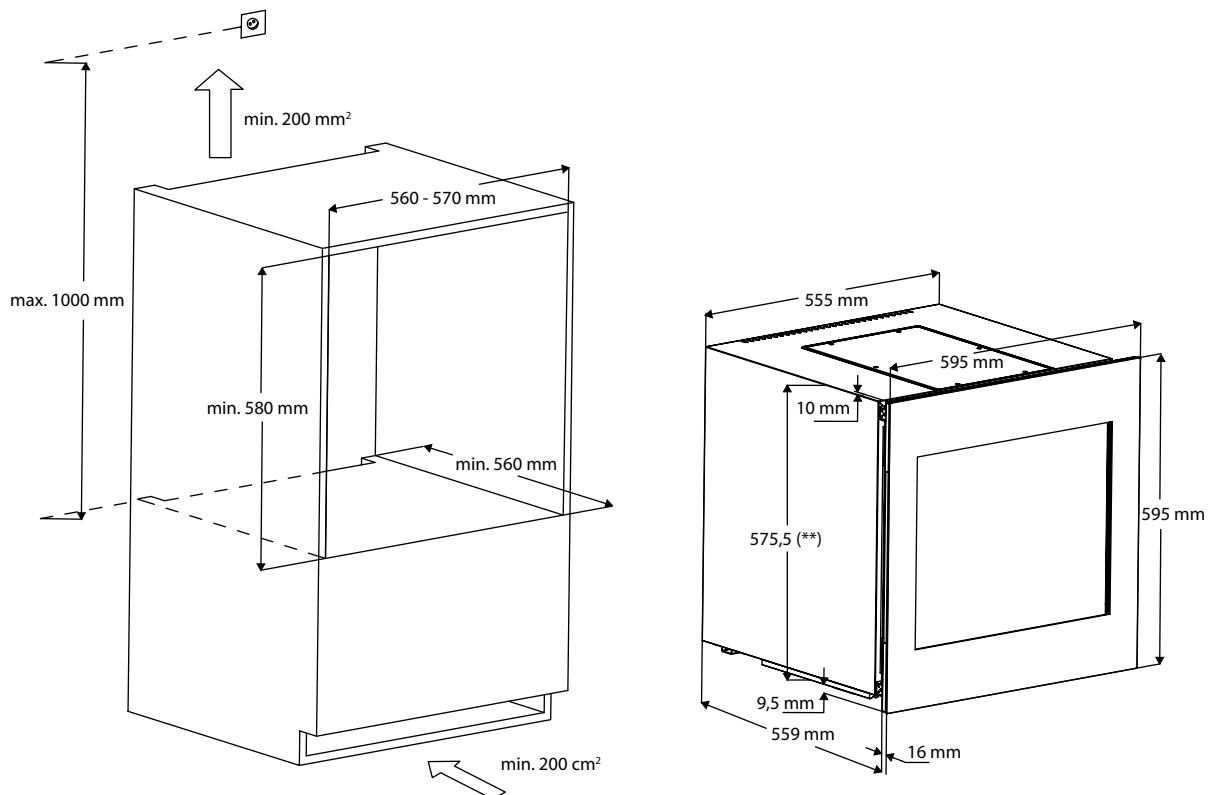

* The installation height can be increased up to 455.5 mm by the adjustable feet.

** The installation height can be increased up to 590.5 mm by the adjustable feet.

WineDeluxe WD 41

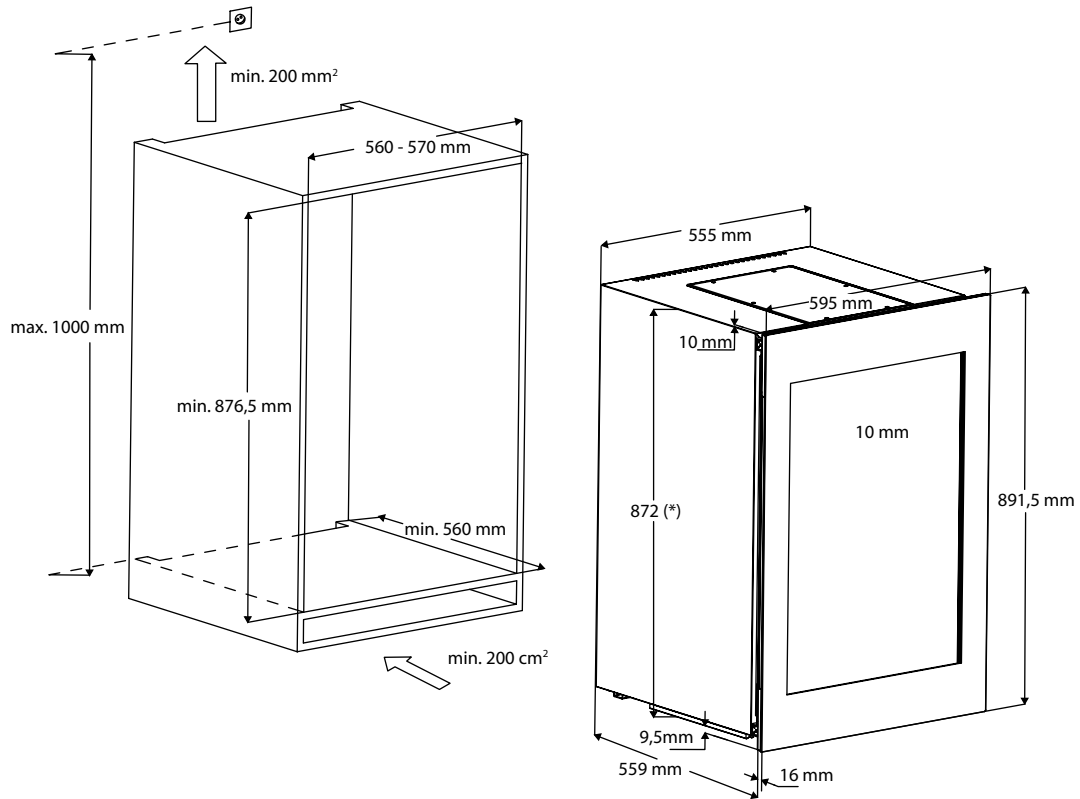

WineDeluxe WD 60

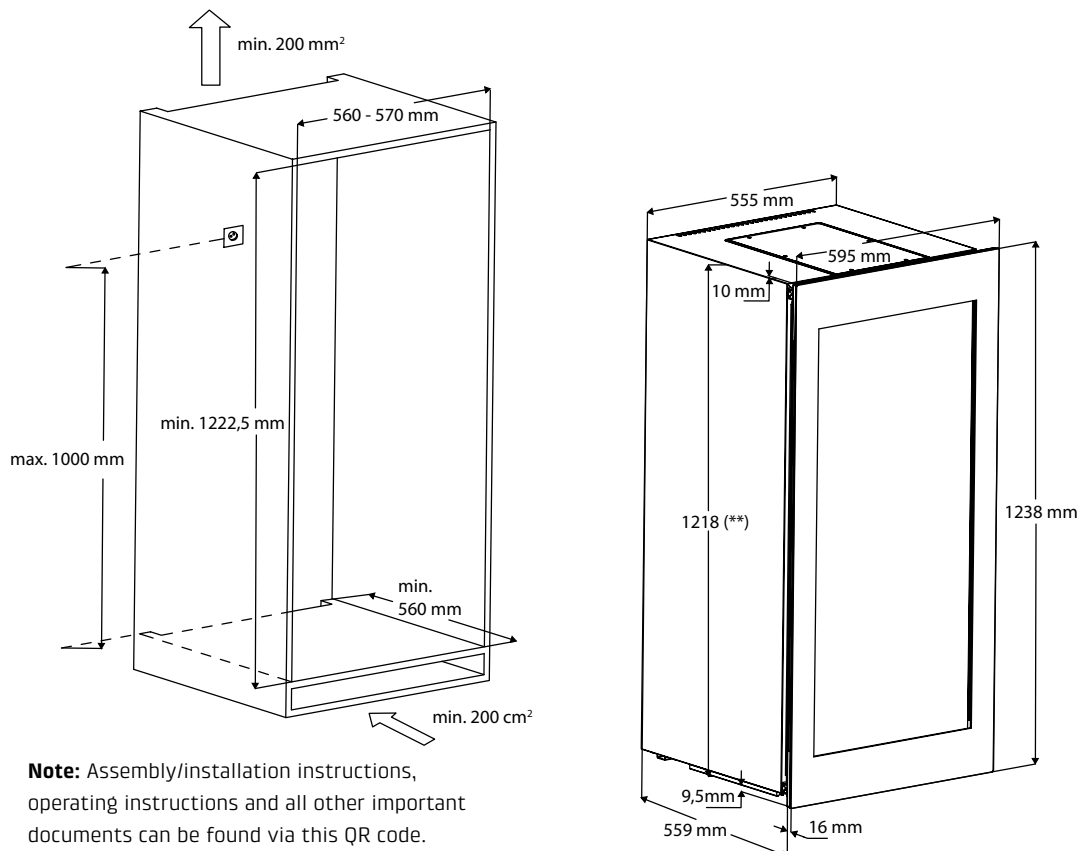

Note: Assembly/installation instructions, operating instructions and all other important documents can be found via this QR code.

* The installation height can be increased up to 887 mm by the adjustable feet.

** The installation height can be increased up to 1233 mm by the adjustable feet.

WineDeluxe WD 96

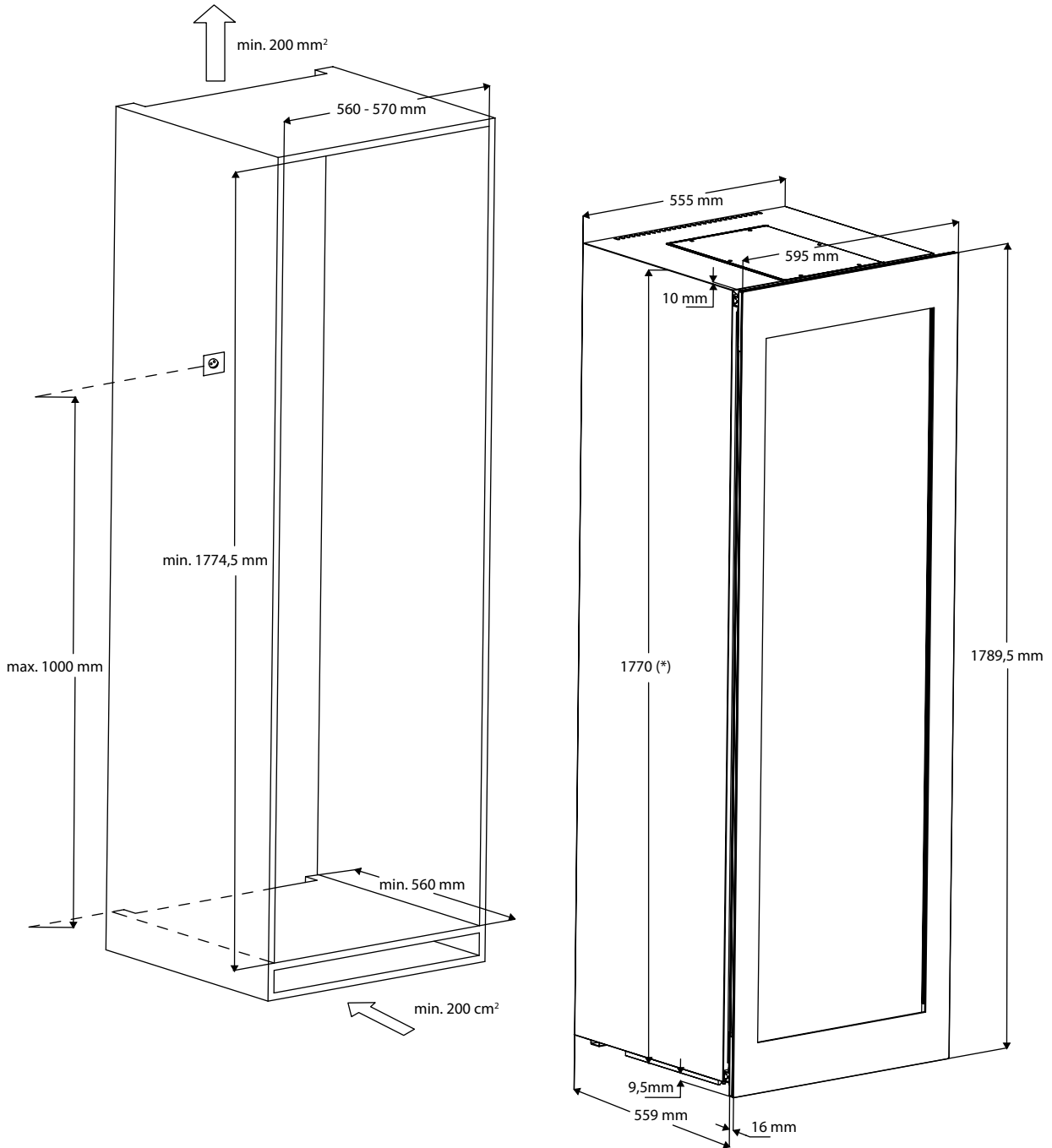

* The installation height can be increased up to **1785 mm** by the adjustable feet.

WineDeluxe WDU 18

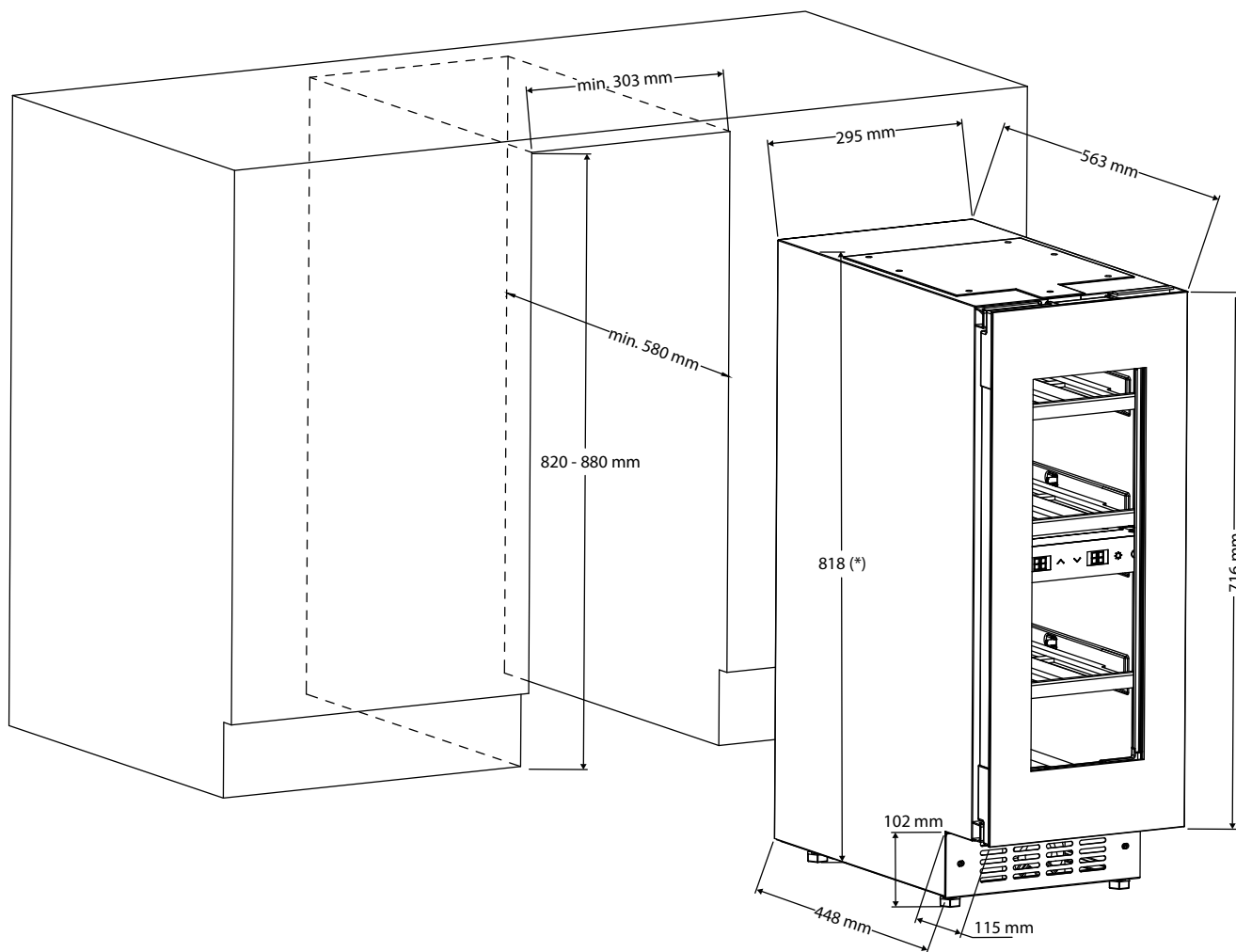

Note: Assembly/installation instructions, operating instructions and all other important documents can be found via this QR code.

* The installation height can be increased up to **878 mm** by the adjustable feet.

WineDeluxe WDU 36

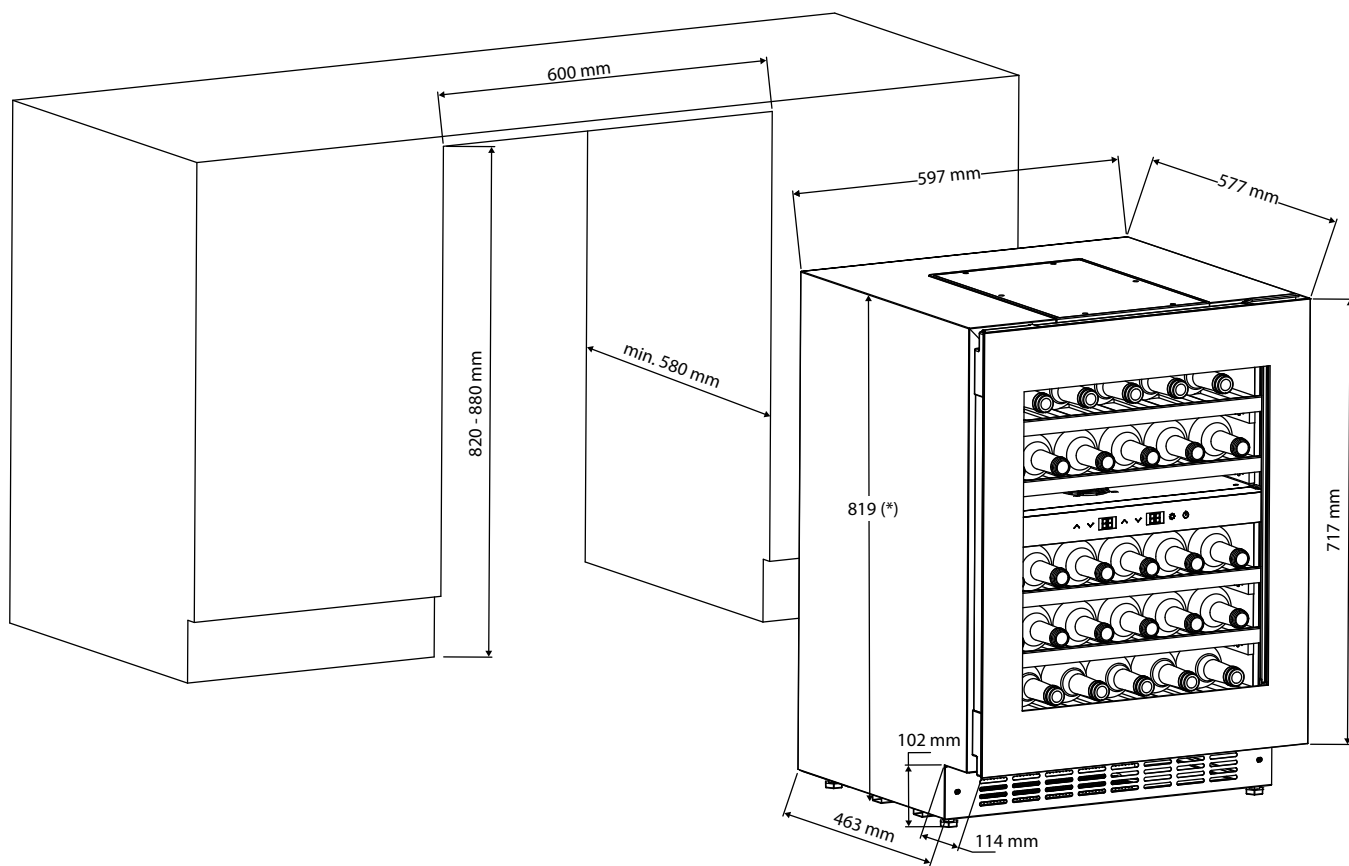

* The installation height can be increased up to 889 mm by the adjustable feet.

WineChef Duo 122 Black

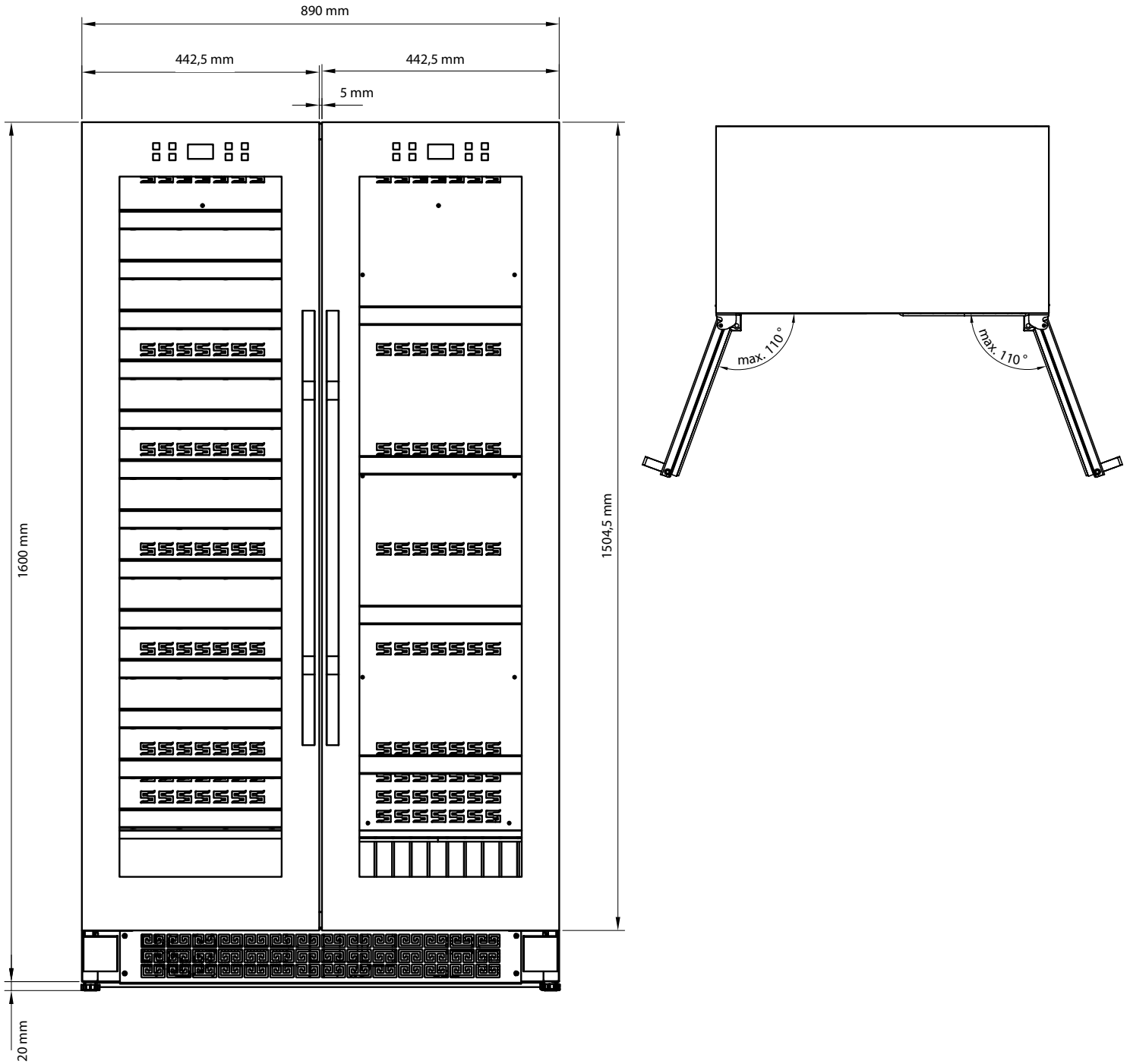

Note: Assembly/installation instructions, operating instructions and all other important documents can be found via this QR code.



Compact cooking pleasure
for heating and baking

Microwaves



SELECTION E 25 MGS



Built-in microwave with grill

- + Built-in designer microwave oven & grill for 38 cm niche height
- + Powerful 900 watt microwave and 1000 watt quartz grill
- + Stainless steel interior with large 25 L capacity oven
- + Elegant "black glass" design
- + LCD display with digital clock
- + Touch control panel for intuitive operation
- + Automatic touch sensor door opener
- + With practical quick start function
- + 5 microwave settings
- + 8 automatic cooking programmes
- + Incl. combination programmes (microwave & grill)
- + With automatic defrosting programme
- + 95-minute cooking timer
- + Big 31.5 cm Ø glass turntable
- + With integrated interior lighting
- + Accessories: Grill rack

Product data

Art. No.:	7320
Weight:	16,2 kg
Dimensions (W*H*D):	595 x 380 x 390 mm
Installation:	560 x 380 x 550 mm (38 niche height)
Capacity:	Ca. 25 Liter
Connection values:	230-240 V / 50-60 Hz
Power:	Microwave 900 W Grill 1000 W

SELECTION E 25 MGS

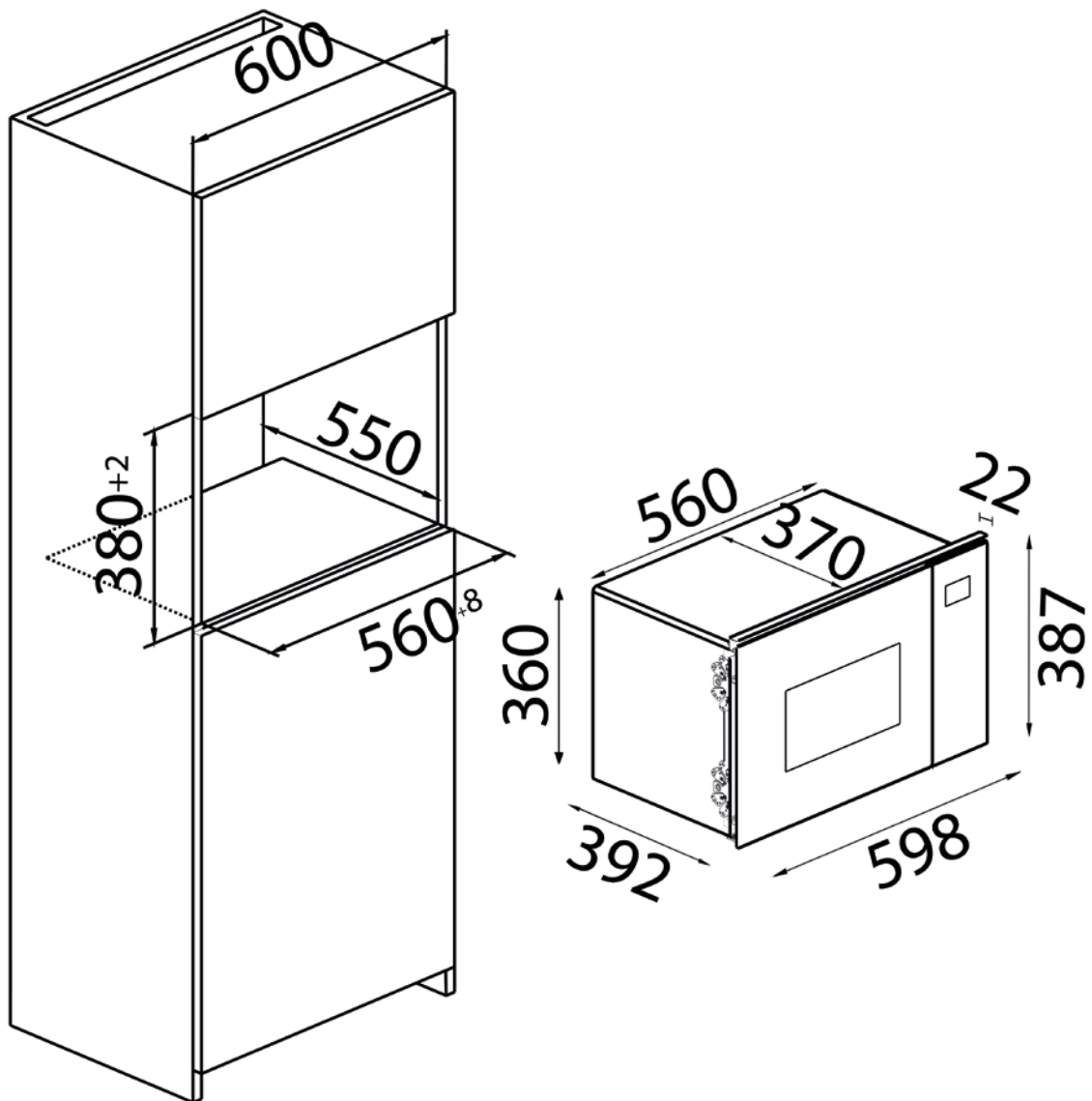



For more freshness
in your home

Vacuum sealer



Seal

Marinate

VacuChef 40



Blum Legrabox 16, Hettich AvanTech

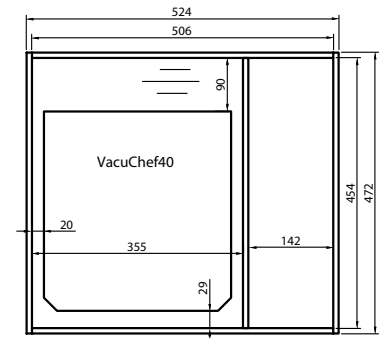

Grass Nova Pro 16

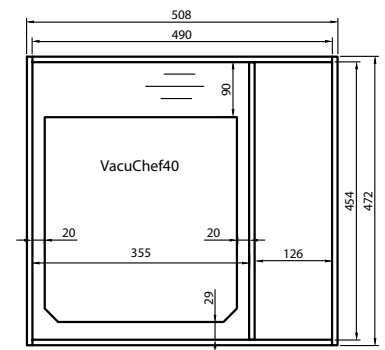

Professional chamber vacuum sealer & Drawer Insert

- + Ideal for keeping fresh and marinating
- + Chamber size W×H×D: 260 × 45 × 260 mm (approx. 3 Liter)
- + **Strong professionell vacuum pump: 70 liters / minute**
- + Almost 100% vacuum
- + **Double weld seam for bags up to a width of 25 cm**
- + With integrated clamping bracket for a firm hold of the vacuum bags
- + Practical progress display
- + **High-quality vacuum sealer: housing made of stainless steel and glass lid made of tempered glass**
- + Combined vacuuming and sealing with individual settings for hard and soft, as well as dry and moist foods
- + Manual sealing
- + Automatic marinating in the bag
- + Also suitable for the vacuuming of vacuum containers (necessary vacuum hose included)
- + **Vacuuming outside of the device also possible with structured bags**
- + **Simple and intuitive operation via touch control panel**

Product data vacuum sealer & Drawer Insert

Blum Legrabox 16, Hettich AvanTech

Art. No.: 7132
Dimensions (W×H×D): 524 × 57 × 472 mm

Grass Nova Pro 16

Art. No.: 7134
Dimensions (W×H×D): 508 × 57 × 472 mm

Technical data VacuChef 40

Weight: ca. 8,4 kg
Dimensions (W×H×D): 320 × 175 × 355 mm
Voltage: 220 - 240 V, 50 Hz
Power: 280 W

VR 390 advanced



Blum Legrabox 16, Hettich AvanTech

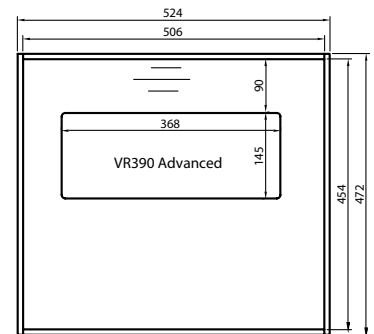

Grass Nova Pro 16

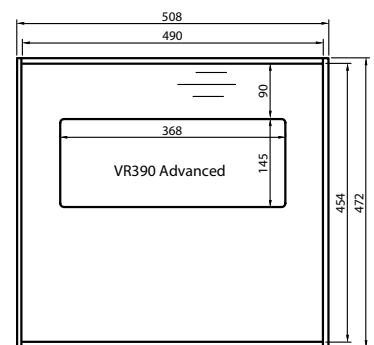

Bar vacuum sealer & Drawer Insert

- + Automatic vacuuming and sealing
- + Adjustable sealing time for dry and moist foods
- + Adjustable vacuum strength (normal / gentle)
- + Manual sealing
- + Vacuum container function
- + For a particularly stable, 2.5 mm thick weld seam up to 30 cm width
- + Multi cycle: Up to 75 cycles non-stop possible
- + Durable vacuum pump with up to 12 liters / min and a maximum negative pressure of -0.8 bar
- + High quality stainless steel design front
- + Removable drip tray for any accumulated liquid
- + Electronic temperature monitoring
- + Incl. 10 free professional vacuum bags (20 x 30 cm) and 1 vacuum hose

Product data vacuum sealer & Drawer Insert

Blum Legrabox 16, Hettich AvanTech

Art. No.: 7126
Dimensions (W×H×D): 524 × 57 × 472 mm

Grass Nova Pro 16

Art. No.: 7128
Dimensions (W×H×D): 508 × 57 × 472 mm

Technical data VR 390 advanced

Weight: ca. 1,47 kg
Dimensions (W×H×D): 365 × 70 × 140 mm
Voltage: 220 - 240 V, 50 Hz
Power: 110 W

Germany

CASO GmbH
Raiffeisenstraße 9
D-59757 Arnsberg

Distribution
Fon +49 (0) 29 32 - 547 66 - 0
Fax +49 (0) 29 32 - 547 66 - 77
vertrieb@caso-design.de

www.caso-design.de

CASOVIDA GmbH
Raiffeisenstraße 9
D-59757 Arnsberg

Distribution
Fon +49 (0) 29 32 - 547 66 - 30
Fax +49 (0) 29 32 - 547 66 - 77
backoffice@casovida.com

Service
Fon +49 (0) 29 32 - 547 66 - 31
service@casovida.com

www.casovida.com